

# GETRÄNKEKÜHLUNG | Minibars

THERMOELEKTRISCHE MINIBAR

## MB 32



### DETAILS



Türschloß als Standard



PCB Regler mit Drehknopf zur Temperaturregulierung



Griff im Türprofil integriert



Türablage



## ARTIKELINFORMATIONEN

30l Minibar mit Absorbertechnik	•
Geräuscharmer Betrieb	•
Geringe Vibrationen	•
Geringer Wartungsaufwand	•
Isolierungsmaterial Cyclopentane (40mm - FCKW frei)	•
Mechanisches Thermostat	•
Innere LED Beleuchtung	•
Türschloß als Standard	•
Türablagen	•
herausnehmbare Türdichtung	•
Höhenverstellbarer Einschub (1 Stück)	•
Griff im Türprofil integriert	•
4 Höhenverstellbare Füße	•
Energieeffizienzklasse: B	•

## TECHNISCHE SPEZIFIKATIONEN

Fassungsvermögen	26 L
Temperatur	+6° ~ +12°C
Verbrauch	0.106 kWh/24h
Nennleistung	60 W
Geräuschpegel	26 dB(A)
Nettogewicht	8 Kg
Bruttogewicht	9 Kg
Außenmaße (BxTxH mm)	380x380x480
Innenmaße (BxTxH mm)	329x209x368
Verpackungsmaße (BxTxH mm)	420x420x495
Lademengen 20'/40'/40'HQ	260/560/700

## ZERTIFIZIERUNGEN

CE RoHS

## PRODUKTABMESSUNGEN

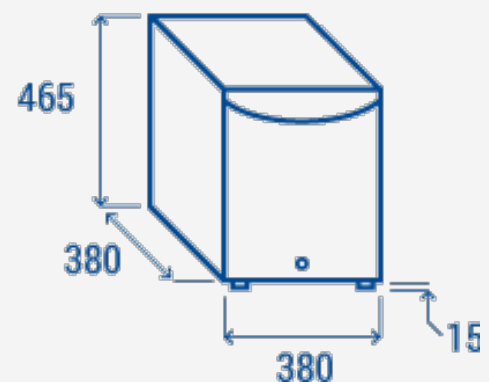

**RIGHTWAY ASIA**

We make the world a cooler place