

GETRÄNKEKÜHLUNG | Minibars

THERMOELEKTRISCHE MINIBAR

MB 52



DETAILS



Türschloß als Standard



PCB Regler mit Drehknopf zur Temperaturregulierung



Griff im Türprofil integriert



Türablage

ARTIKELINFORMATIONEN

50l Minibar mit Absorbertechnik	•
Geräuscharmer Betrieb	•
Geringe Vibrationen	•
Geringer Wartungsaufwand	•
Isolierungsmaterial Cyclopentane (40mm - FCKW frei)	•
Mechanisches Thermostat	•
Innere LED Beleuchtung	•
Türschloß als Standard	•
Türablagen	•
herausnehmbare Türdichtung	•
Höhenverstellbarer Einschub (1 Stück)	•
Griff im Türprofil integriert	•
4 Höhenverstellbare Füße	•
Energieeffizienzklasse: C	•

TECHNISCHE SPEZIFIKATIONEN

Fassungsvermögen	48.5 L
Temperatur	+6° ~ +12°C
Verbrauch	0.134 kWh/24h
Nennleistung	60 W
Geräuschpegel	26 dB(A)
Nettogewicht	10 Kg
Bruttogewicht	12 Kg
Außenmaße (BxTxH mm)	430x494x515
Innenmaße (BxTxH mm)	356x336x410
Verpackungsmaße (BxTxH mm)	460x515x530
Lademengen 20'/40'/40'HQ	220/460/572

ZERTIFIZIERUNGEN

CE RoHS

PRODUKTABMESSUNGEN

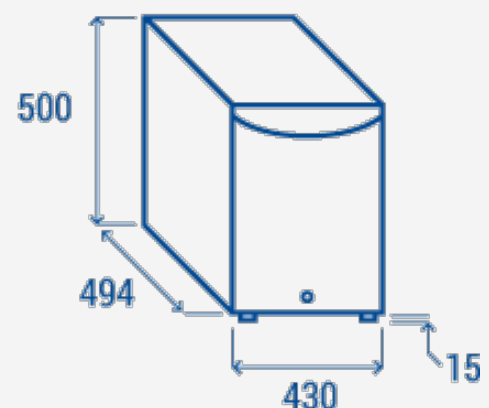

RIGHTWAY ASIA

We make the world a cooler place