

VITRINEN | Countertop Vitrinen

PRÄSENTATIONS KÜHLVITRINEN

RG 1200



DETAILS



Digitales Thermostat

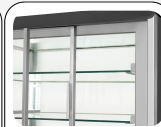

Höhenverstellbare Glaseinschübe



Interne LED Beleuchtung



ARTIKELINFORMATIONEN

- Eckiger Glasaufsatz mit schwarzem Rahmen und Unterkonstruktion aus Edelstahl
- Umluftkühlung
- Verdampfer mit Anti- Korrosions Behandlung
- Automatische Abtauung durch Kompressor Stop
- Steuerung mit Digitalanzeige
- Innere LED Beleuchtung
- Doppelsicherheitsglas mit niedrigem Emmissionsgrad (Low-E)
- Schiebetüren auf der Rückseite
- Höhenverstellbare Glaseinschübe (2 Stück)
- 4 Höhenverstellbare Füße
- Energieeffizienzklasse: C

TECHNISCHE SPEZIFIKATIONEN

Fassungsvermögen	280 L
Temperatur	M1 (-1°C-+5°C)
Verbrauch	8.1 kWh/24h
Nennleistung	500 W
Geräuschpegel	50 dB(A)
Nettogewicht	120.00 Kg
Bruttogewicht	148.00 Kg
Außenmaße (BxTxH mm)	1192x676x731
Innenmaße (BxTxH mm)	1150x613x409
Verpackungsmaße (BxTxH mm)	1260x750x850
Lademengen 20'/40'/40'HQ	26/54/81

ZERTIFIZIERUNGEN



PRODUKTABMESSUNGEN

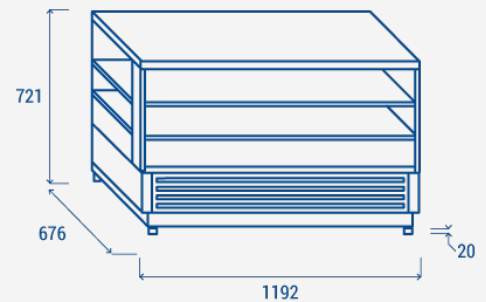

RIGHTWAY ASIA
We make the world a cooler place