

# DRINKS | Backbars

BACK BARS ► HINGED DOORS



## GENERAL FEATURES

- N.2 Hinged door BACK BAR (Height 900mm)
- Aluminium for internal and black coated steel for external side
- Item with shiny finishing and total height at 900mm
- Roll-bond evaporator system with fan assisted cooling
- Automatic compressor cycle defrost
- Foaming Agent Cyclopentane (40mm per side)
- Digital Thermostat
- Self Closing Door
- Removable Gasket
- Adjustable shelves: 4 Pcs
- Toughened safety tempered glass
- Lock fitted as standard
- Inner horizontal LED light
- N.4 Adjustable feet
- Energy efficiency class: B

## TECHNICAL SPECIFICATIONS

Capacity	<b>201 L</b>
Temperature	<b>M1 (-1° - +5°)</b>
Consumption	<b>2.17 kWh/24h</b>
Rated Power	<b>230 W</b>
Noise level	<b>60 dB(A)</b>
Net Weight	<b>62 Kg</b>
Gross Weight	<b>73 Kg</b>
External Dimensions (WxDxH mm)	<b>900x520x900</b>
Internal Dimensions (WxDxH mm)	<b>820x420x750</b>
Packaging dimensions (WxDxH mm)	<b>960x570x980</b>
Loading quantities 20'/40'/40"HQ	<b>48/96/96</b>

## CERTIFICATION

CE RoHS



# BBC 208H

**CUSTOMIZATION AVAILABLE**  
PERSONALIZZAZIONE DISPONIBILE

+1° | +10°

40 mm | M1 | -1°C | +5°C | **B** ENERGY CLASS | 3 | +25°C/60RH

LED | GAS R600a | LED

## DETAILS



## PRODUCT DIMENSIONS

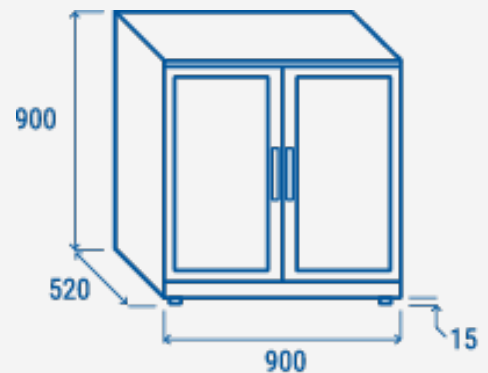

**RIGHTWAY ASIA**  
We make the world a cooler place