

# INOX | Upright Cabinets

BAKERY REFRIGERATED CABINETS ▶ VENTILATED ▶ FREEZER



## GENERAL FEATURES

- EURONORM Freezer upright cabinet
- Stainless Steel exterior and interior
- Ventilated Cooling
- Evaporator and condenser with anti-corrosion treatment
- Bottom side engine room (for comfortable storage in the cabinet)
- Hot gas defrost system
- Digital thermostat with "opening door" and "High temperature" alarm
- Foaming Agent Cyclopentane (80mm)
- Removable Gasket
- LED light and lock fitted as standard
- Door: Self closing and reversible door fitted as standard
- Set of 10 slides for bakery tray 600X400
- Plastic thermal-braker as chamber body frame (Hot pipe system)
- Pressure valve for easily opening door
- N.4 Adjustable feet - S/S feet or castor with brake (Option)
- Energy efficiency class: D

## TECHNICAL SPECIFICATIONS

Capacity	<b>600 L</b>
Temperature	<b>-18° ~ -22°C</b>
Consumption	<b>6.1 kWh/24h</b>
Rated Power	<b>420W</b>
Noise level	<b>48 dB(A)</b>
Net Weight	<b>150 Kg</b>
Gross Weight	<b>161 Kg</b>
External Dimensions (WxDxH mm)	<b>740x880x2025</b>
Internal Dimensions (WxDxH mm)	<b>580x710x1430</b>
Packaging dimensions (WxDxH mm)	<b>760x900x2150</b>
Loading quantities 20'/40'/40"HQ	<b>18/39/39</b>

## CERTIFICATION

CE RoHS

# BNX 740V



## DETAILS

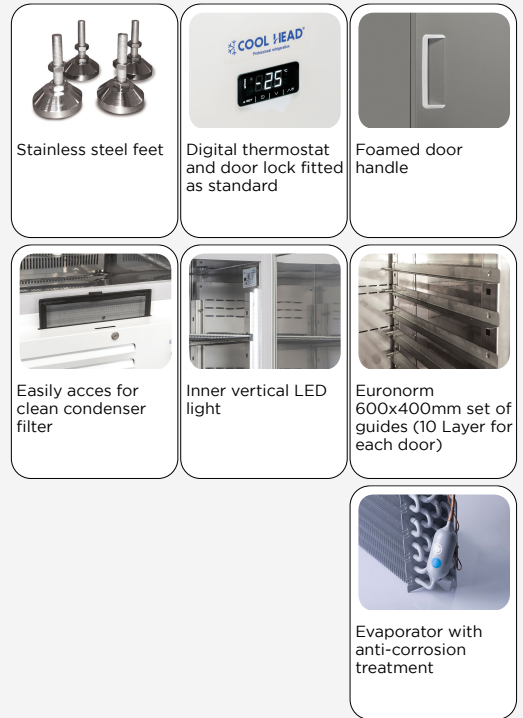

## PRODUCT DIMENSIONS

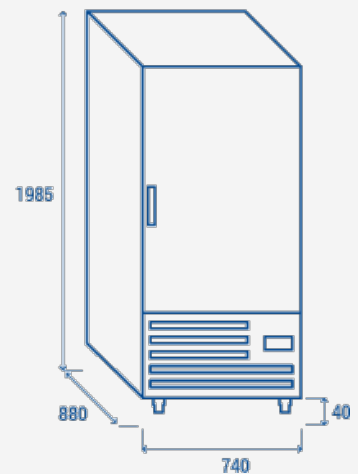

**RIGHTWAY ASIA**  
We make the world a cooler place