

INOX | Upright Cabinets

BAKERY REFRIGERATED CABINETS ▶ STATIC ▶ CHILLER



GENERAL FEATURES

- EURONORM refrigerated upright cabinet
- Stainless Steel exterior and interior
- Static cooling system with fan assisted cooling
- Condenser with anti-corrosion treatment
- Bottom side engine room (for comfortable storage in the cabinet)
- Automatic compressor cycle defrost
- Digital thermostat with "opening door" and "High temperature" alarm
- Foaming Agent Cyclopentane (80mm)
- Removable Gasket
- LED light and lock fitted as standard
- Door: Self closing and reversible door fitted as standard
- Set of 10 slides for bakery tray 600X400
- Plastic thermal-braker anti-condensation as chamber body frame
- N.4 Adjustable feet - S/S feet or castor with brake (Option)
- Energy efficiency class: D

TECHNICAL SPECIFICATIONS

Capacity	600 L
Temperature	+2° - +8°C
Consumption	2.5 kWh/24h
Rated Power	350 W
Noise level	48 dB(A)
Net Weight	150 Kg
Gross Weight	161 Kg
External Dimensions (WxDxH mm)	740x880x2025
Internal Dimensions (WxDxH mm)	580x710x1430
Packaging dimensions (WxDxH mm)	760x900x2150
Loading quantities 20'/40'/40'HQ	18/39/39

CERTIFICATION

CE RoHS



BYX 740S



BAKERY



TROPICALIZED UPRIGHT



COMFORTABLE STORAGE GOODS

GAS
R290

80 mm

5
CLIMATIC CLASS

40°C

LED

DETAILS



Stainless steel feet



Digital thermostat and door lock fitted as standard



Foamed door handle



Easily access for clean condenser filter



Inner vertical LED light



Euronorm 600x400mm set of guides (10 Layer for each door)



Bottom hole for easily clean and dry the item

PRODUCT DIMENSIONS

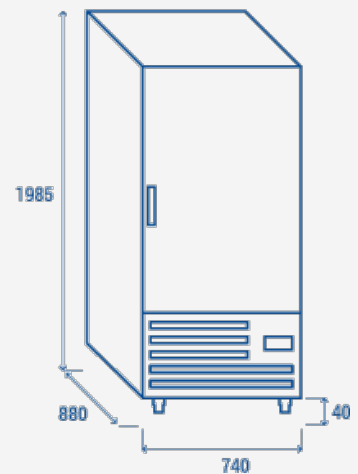

RIGHTWAY ASIA
We make the world a cooler place