

FREEZER | Chestfreezers

CHEST FREEZER ▶ STANDARD TOP

CF 300A

CUSTOMIZATION AVAILABLE
PERSONALIZZAZIONE DISPONIBILE

-23° | -18°



GAS
R600a

70 mm

E
ENERGY CLASS

T +16°C/+43°C



DETAILS



The items can be supplied either with lockable castor



Handle with lock



Basket included



Digital control panel with alarm



GENERAL FEATURES

- 300 Lt. Chest freezer with standard top
- White coated steel for external, embossed aluminium internally
- Static Cooling
- Manual Defrost
- Defrost water drain
- Foaming Agent Cyclopentane (70mm per side)
- Removable Gasket
- Interior LED light
- Handle with lock
- Digital control panel with alarm
- Independent main switch
- Basket included (N.2 Pcs)
- N.4 Adjustable feet
- Energy efficiency class: E

TECHNICAL SPECIFICATIONS

Capacity	304 L
Temperature	-15° ~ -25°C
Consumption	0.783 kWh/24h
Rated Power	84 W
Noise level	48 dB(A)
Net Weight	44 Kg
Gross Weight	52 Kg
External Dimensions (WxDxH mm)	1035x750x850
Internal Dimensions (WxDxH mm)	890x530x665
Packaging dimensions (WxDxH mm)	1080x760x990
Loading quantities 20'/40'/40"HQ	32/66/66

CERTIFICATION

CE RoHS

PRODUCT DIMENSIONS

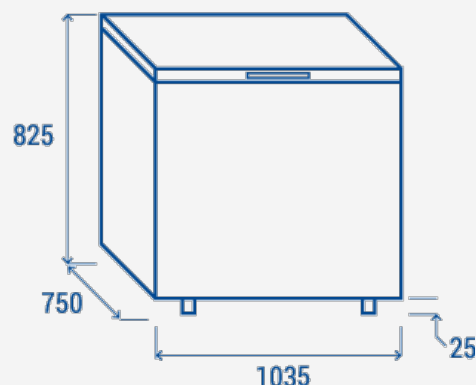

RIGHTWAY ASIA
We make the world a cooler place