

Freezer | Chestfreezers

CHEST FREEZER ▶ GLASS TOP

CG 150

CUSTOMIZATION AVAILABLE
PERSONALIZZAZIONE DISPONIBILE

70 mm	C1 -18°C	D ENERGY CLASS	B +16°C/80RH +35°C/75RH
LED	Key	Wash	GAS R290

DETAILS



Castor included in the packaging (To be assembled)

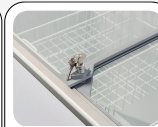

Lock fitted as standard



Basket included



General features

- 150 Lt. Chest freezer with sliding glass top
- White coated steel for external and internal
- Static Cooling
- Manual Defrost
- Analog thermometer
- Foaming Agent Cyclopentane (70mm per side)
- Single tempered safety glass
- Handle on the glass frame
- Lock fitted as standard
- Independent switch for internal light and canopy
- Basket included (N.2 Pcs)
- N.4 Castor (N.2 in the front with brake)
- Energy efficiency class: D

Technical specifications

Capacity	137 L
Temperature	C1 (-18°C)
Consumption	1.863 kWh/24h
Rated Power	113 W
Noise level	47 dB(A)
Net Weight	47 Kg
Gross Weight	54 Kg
External Dimensions (WxDxH mm)	584x694x850
Internal Dimensions (WxDxH mm)	440x550x589
Packaging dimensions (WxDxH mm)	625x770x895
Loading quantities 20'/40'/40"HQ	54/114/169

PRODUCT DIMENSIONS

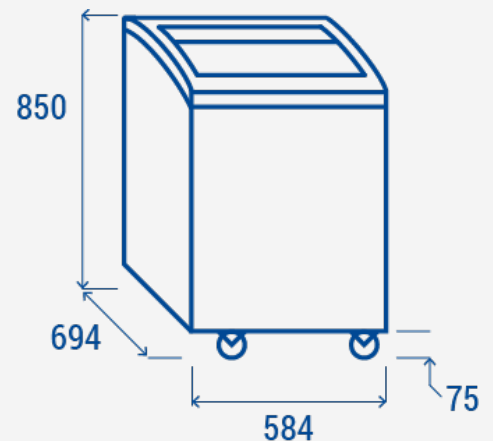

CERTIFICATION

CE RoHS



RIGHTWAY ASIA
We make the world a cooler place