

ABS | Upright Cabinets

FREEZER UPRIGHT ▶ GLASS DOOR ▶ INOX



CNXG 2



DETAILS



GENERAL FEATURES

- 200 Lt. Freezer upright (GLASS DOOR)
- S/S external cabinet, thermoformed internally
- Static cooling: fixed evaporator shelves (N.3 Layers)
- Manual Defrost
- Foaming Agent Cyclopentane (50mm per side)
- Digital Thermostat
- Triple heated safety tempered glass
- Opening door alarm/High temperature alarm
- Removable Gasket
- Lock and main switch fitted as standard
- N.2 Adjustable feet + N.2 Rollers at the back
- Stainless steel external handle
- Energy efficiency class: -

TECHNICAL SPECIFICATIONS

Capacity	200 L
Temperature	-21° - -18°C
Consumption	2.15 kWh/24h
Rated Power	174 W
Noise level	40 dB(A)
Net Weight	50 Kg
Gross Weight	54.3 Kg
External Dimensions (WxDxH mm)	598x679x838
Internal Dimensions (WxDxH mm)	493x478x635
Packaging dimensions (WxDxH mm)	650x680x880
Loading quantities 20'/40'/40"HQ	48/108/162

PRODUCT DIMENSIONS

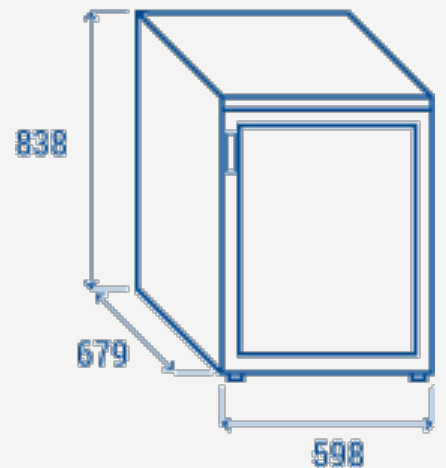

CERTIFICATION



RIGHTWAY ASIA
We make the world a cooler place