

INOX | Saladette

SALADETTE ▶ GN1/1 ▶ OPEN TOP

CR 90A



DETAILS



GENERAL FEATURES

- GN1/1 Refrigerated saladette (OPEN TOP)
- Stainless Steel exterior and interior
- Static Cooling
- Automatic compressor cycle defrost
- Foaming Agent Cyclopentane (45mm per side)
- Digital Thermostat
- Sliding engine room for a manageable after sales servicing
- Plastic thermal-braker as chamber body frame
- Easy removable condenser filter
- Separated plastic water tray
- Front panel tilted holes for better air circulation
- Adjustable shelves GN1/1: 2 Pcs
- Self closing door (New inner embossed design for a better sealing)
- Removable Gasket
- Engine room lock fitted as standard
- N.2 Adjustable feet in the front + N.4 fix rollers
- Holder spacer for GN pans with "hook" design (included)
- Energy efficiency class: -

TECHNICAL SPECIFICATIONS

Capacity	232L
Temperature	+0° - +8°C
Consumption	2.42 kWh/24h
Rated Power	142.4 W
Noise level	53.9 dB(A)
Net Weight	70 Kg
Gross Weight	88 Kg
External Dimensions (WxDxH mm)	900x700x883
Internal Dimensions (WxDxH mm)	810x586x502
Packaging dimensions (WxDxH mm)	950x750x1030
Loading quantities 20'/40'/40"HQ	36/72/72

PRODUCT DIMENSIONS

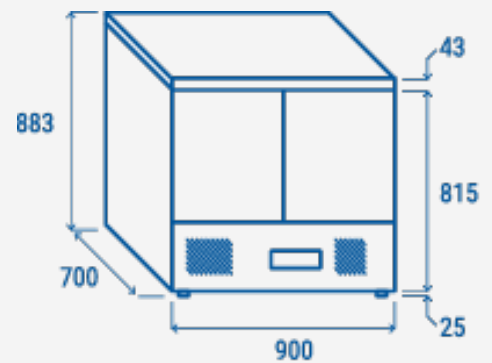

CERTIFICATION

CE RoHS



RIGHTWAY ASIA
We make the world a cooler place