

INOX | Saladette

SALADETTE ▶ GN1/1 ▶ OPEN TOP

CR 92A



DETAILS



GENERAL FEATURES

- GN1/1 Refrigerated saladette (OPEN TOP)
- Stainless Steel exterior and interior
- Static Cooling
- Automatic compressor cycle defrost
- Foaming Agent Cyclopentane (45mm per side)
- Digital Thermostat
- Sliding engine room for a manageable after sales servicing
- Plastic thermal-braker as chamber body frame
- Easy removable condenser filter
- Separated plastic water tray
- Front panel tilted holes for better air circulation
- Adjustable shelves GN1/1: 2 Pcs
- Self closing door (New inner embossed design for a better sealing)
- Removable Gasket
- Engine room lock fitted as standard
- N.2 Adjustable feet in the front + N.4 fix rollers
- Holder spacer for GN pans with "hook" design (included)
- Energy efficiency class: -

TECHNICAL SPECIFICATIONS

Capacity	269L
Temperature	+0° - +8°C
Consumption	2.453 kWh/24h
Rated Power	182 W
Noise level	50 dB(A)
Net Weight	75 Kg
Gross Weight	92 Kg
External Dimensions (WxDxH mm)	1045x700x883
Internal Dimensions (WxDxH mm)	955x586x502
Packaging dimensions (WxDxH mm)	1100x750x1030
Loading quantities 20'/40'/40"HQ	30/60/60

PRODUCT DIMENSIONS

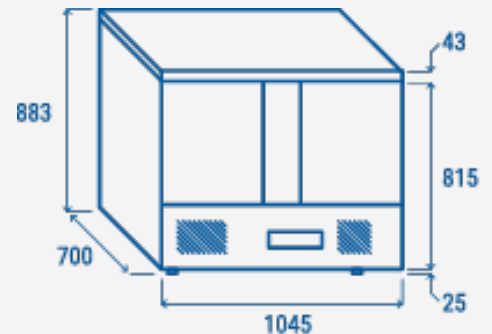

CERTIFICATION



RIGHTWAY ASIA
We make the world a cooler place