

INOX | Saladette

SALADETTE ▶ GN1/1 ▶ PIZZA TOP



General features

- GN1/1 Refrigerated saladette (PIZZA TOP)
- Stainless Steel exterior and interior
- Granite top (WHITE Coor)
- Static Cooling
- Automatic compressor cycle defrost
- Foaming Agent Cyclopentane (45mm per side)
- Digital Thermostat
- Sliding engine room for a manageable after sales servicing
- Plastic thermal-braker as chamber body frame
- Easy removable condenser filter
- Separated plastic water tray
- Front panel tilted holes for better air circulation
- Adjustable shelves GN1/1: 2 Pcs
- Self closing door (New inner embossed design for a better sealing)
- Removable Gasket
- Engine room lock fitted as standard
- N.2 Adjustable feet in the front + N.4 fix rollers
- Energy efficiency class: C

Technical specifications

| | |
|----------------------------------|---------------------|
| Capacity | 214L |
| Temperature | +0° - +8°C |
| Consumption | 2.25 kWh/24h |
| Rated Power | 142.4 W |
| Noise level | 50 dB(A) |
| Net Weight | 86 Kg |
| Gross Weight | 136 Kg |
| External Dimensions (WxDxH mm) | 900x700x870 |
| Internal Dimensions (WxDxH mm) | 810x586x472 |
| Packaging dimensions (WxDxH mm) | 960x750x1030 |
| Loading quantities 20'/40'/40'HQ | 36/72/72 |

CERTIFICATION

CE RoHS

CRZ 90A



GAS
R600a

45 mm

4
CLIMATIC CLASS

36°C

DETAILS

Main switch and digital thermostat fitted as standard

Curved edge for easy cleaning

Engine room lock fitted as standard

Anti-condensation thermal-braker on door frame

Inner embossed door design for a better sealing

Sliding engine easy to pull out for manageable after sales servicing

Granite top WHITE Color

Inner assistance fan

Door design

PRODUCT DIMENSIONS

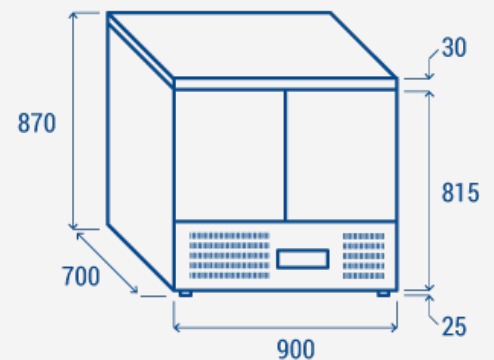

RIGHTWAY ASIA
We make the world a cooler place