

DRINKS | Drink Cabinets

DRINK COOLER ▶ DC LINE ▶ SLIDING DOORS

DC 1000S

CUSTOMIZATION AVAILABLE
PERSONALIZZAZIONE DISPONIBILE

+1° | +10°

45 mm | K2 | -1°C / +6°C | D ENERGY CLASS | CC3 | +40°C / 75RH | LED | Lock | Fan | GAS R290

DETAILS



Independent light switches for inner light and canopy



Digital Thermostat



Inner vertical LED light



Lock fitted as standard



GENERAL FEATURES

- 1000 Lt. Upright drink cooler
- White coated steel for internal and external side
- Ventilated Cooling
- Automatic compressor cycle defrost
- Foaming Agent Cyclopentane (45mm per side)
- Digital Thermostat
- Self Closing Door
- Removable Gasket
- Adjustable shelves: 8 Pcs
- Independent switches for internal light and canopy
- Toughened safety tempered glass
- Lock fitted as standard
- Inner vertical LED light / LED for canopy
- N.4 Wheels for easy positioning
- Energy efficiency class: D

TECHNICAL SPECIFICATIONS

Capacity	1000 L
Temperature	K2 (-1°C-+6°C)
Consumption	3.534 kWh/24h
Rated Power	650 W
Noise level	64 dB(A)
Net Weight	159 Kg
Gross Weight	191.5 Kg
External Dimensions (WxDxH mm)	1200x730x2038
Internal Dimensions (WxDxH mm)	1070x530x1525
Packaging dimensions (WxDxH mm)	1255x770x2136
Loading quantities 20'/40'/40"HQ	13/27/27

PRODUCT DIMENSIONS

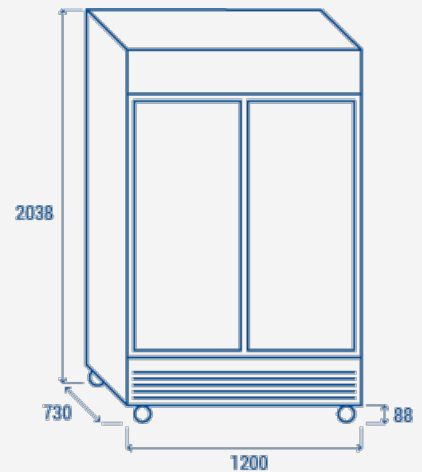

CERTIFICATION

CE RoHS



RIGHTWAY ASIA
We make the world a cooler place