

DRINKS | Drink Cabinets

DRINK COOLER ▶ UPRIGHT COOLERS ▶ BLACK PAINTED



GENERAL FEATURES

- 350 Lt. Upright drink cooler
- External in black coated plate, black thermoformed internally
- Roll-bond evaporator system with fan assisted cooling
- Automatic compressor cycle defrost
- Foaming Agent Cyclopentane (40mm per side)
- Digital Thermostat
- Double inner vertical LED light
- Independent switch for internal light
- Black aluminium "frameless" door with Safety tempered glass
- Self Closing Door
- Aluminium external handle (Black Color)
- Lock fitted as standard
- Removable Gasket
- Black adjustable shelves: 5 Pcs
- N.2 rear wheels+frontal feet for easy positioning + N.2 feet anti-tilted
- Energy efficiency class: D

TECHNICAL SPECIFICATIONS

Capacity	360 L
Temperature	K4 (1°C-+9°C)
Consumption	1.901 kWh/24h
Rated Power	180 W
Noise level	46 dB(A)
Net Weight	72 Kg
Gross Weight	87 Kg
External Dimensions (WxDxH mm)	685x680x1755
Internal Dimensions (WxDxH mm)	540x484x1505
Packaging dimensions (WxDxH mm)	665x665x1920
Loading quantities 20'/40'/40"HQ	24/54/54

CERTIFICATION

CE RoHS

DC 350BF

CUSTOMIZATION AVAILABLE
PERSONALIZZAZIONE DISPONIBILE

+1° | +10°

40 mm

K4
+1°C
+9°C

D
ENERGY CLASS

CC3
+40°C
75RH

KEY

DOOR

FAN

LED

GAS
R600a

DETAILS

Digital Thermostat

Painted aluminium door frame

Double inner vertical LED light

Internally thermoformed

Inner assistance fan

Aluminium external handle

Temperate glass with silk printing

Rear folder spacer fitted as standard

PRODUCT DIMENSIONS

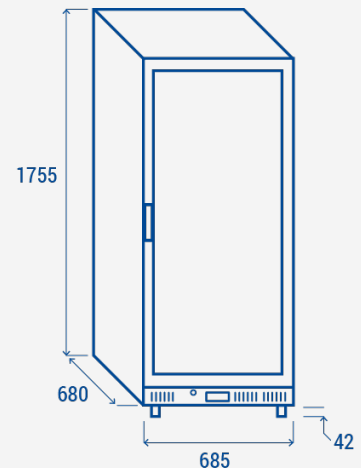

RIGHTWAY ASIA
We make the world a cooler place