

INOX | Dual temperature drawers

DUAL TEMPERATURE ▶ GN1/1 ▶ REFRIGERATED DRAWERS

DWT 92



-
-
- GAS**
R290
- 50 mm
- 4**
CLIMATIC CLASS
- 38°C
- GN 1/1**

150 mm

DETAILS



Wheels for easy positioning



Main switch and digital thermostat fitted as standard



Sliding engine easy to pull out for manageable after sales servicing



Easily access for clean condenser filter



Evaporator with anti-corrosion treatment



Removable Gasket

General features

- Double drawers switchable cooling/freezer (N.4 GN1/1 Pans)
- Dual temperature model (Easily switchable between cooler and freezer)
- Stainless Steel exterior and interior
- Ventilated Cooling
- Automatic defrost with electric heater
- Evaporator with anti-corrosion treatment
- Foaming Agent Cyclopentane (50mm per side)
- Digital Thermostat
- Sliding engine room for a manageable after sales servicing
- Easy removable condenser filter
- Front panel tilted holes for better air circulation
- Sliding drawers GN1/1 suitable for pans 150mm depth
- Removable Gasket
- N.4 Castor (N.2 in the front with brake)
- Energy efficiency class: -

Technical specifications

Capacity	179 L
Temperature	-2°--+8°C/-21°--18°C
Consumption	4.4/13 kWh/24h
Rated Power	689 W
Noise level	42 dB(A)
Net Weight	135 Kg
Gross Weight	150 Kg
External Dimensions (WxDxH mm)	905x700x870
Internal Dimensions (WxDxH mm)	626x520x150
Packaging dimensions (WxDxH mm)	945x740x945
Loading quantities 20'/40'/40"HQ	36/74/74

CERTIFICATION

CE RoHS

PRODUCT DIMENSIONS

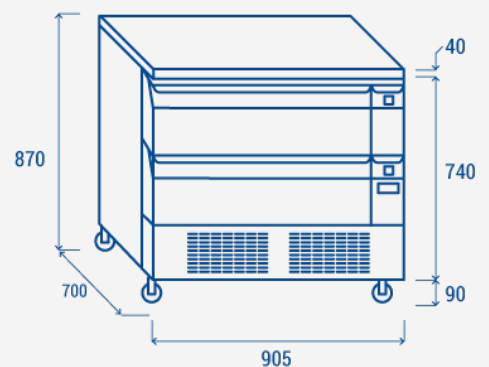

RIGHTWAY ASIA
We make the world a cooler place