

INOX | Upright Cabinets

ICE CREAM CABINETS ▶ VENTILATED ▶ FREEZER



GENERAL FEATURES

- GN2/1 Freezer upright cabinet
- Stainless Steel exterior and interior
- Ventilated Cooling
- Evaporator and condenser with anti-corrosion treatment
- Bottom side engine room (for comfortable storage in the cabinet)
- Hot gas defrost system
- Digital thermostat with "opening door" and "High temperature" alarm
- Foaming Agent Cyclopentane (80mm)
- Removable Gasket
- LED light and lock fitted as standard
- Door: Self closing and reversible door fitted as standard
- Adjustable shelves GN2/1: 9 Pcs
- Plastic thermal-braker as chamber body frame (Hot pipe system)
- GN 1/3 Ice cream pans (150mm - Depth) capacity: 46 pcs
- 360x165x120mm Ice cream pans (5 Litres) capacity: 54 pcs
- N.4 Adjustable feet / Castor with brake (Option)
- Energy efficiency class: D

TECHNICAL SPECIFICATIONS

Capacity	600 L
Temperature	-18° ~ -25°C
Consumption	6.381 kWh/24h
Rated Power	420 W
Noise level	48 dB(A)
Net Weight	150 Kg
Gross Weight	161 Kg
External Dimensions (WxDxH mm)	740x880x2025
Internal Dimensions (WxDxH mm)	580x710x1430
Packaging dimensions (WxDxH mm)	760x900x2150
Loading quantities 20'/40'/40"HQ	18/39/39

CERTIFICATION

CE RoHS



GEX 688V



DETAILS

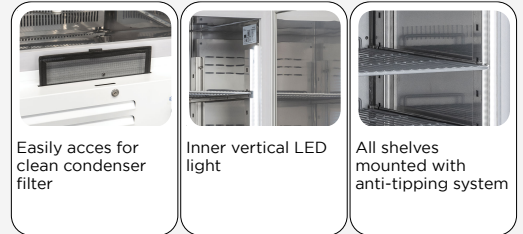

PRODUCT DIMENSIONS

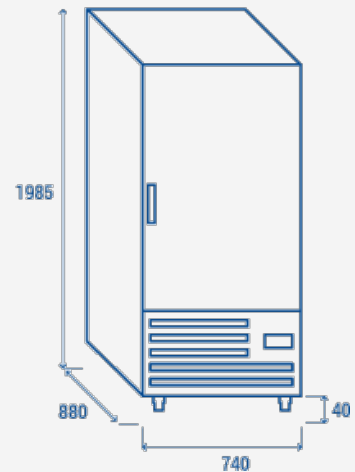

RIGHTWAY ASIA
We make the world a cooler place