

# ABS | Upright Cabinets

FREEZER UPRIGHT ▶ VENTILATED ▶ WHITE PAINTED

GF 2V



## General features

- 200 Lt. Ventilated Freezer ABS upright (GLASS FROST) •
- White external cabinet, thermoformed internally •
- Workable stainless steel top •
- Ventilated Cooling •
- Automatic defrost with electric heater •
- Evaporator with anti-corrosion treatment •
- Foaming Agent Cyclopentane (50mm per side) •
- Digital Thermostat •
- Special temperature range (+5°C--12°C) for frozen glasses •
- Triple heated safety tempered glass •
- Opening door alarm/High temperature alarm •
- Removable Gasket •
- Lock fitted as standard •
- Independent back-lit main switch (Blue color) •
- Inner horizontal LED light (with independent switch) •
- N.2 Adjustable feet + N.2 Rollers at the back •
- Stainless steel external handle •
- Energy efficiency class: - •

## Technical specifications

Capacity	141 L
Temperature	L2 (+5°C--12°C)
Consumption	4.71 kWh/24h
Rated Power	230 W
Noise level	40 dB(A)
Net Weight	39 Kg
Gross Weight	44 Kg
External Dimensions (WxDxH mm)	598x699x839
Internal Dimensions (WxDxH mm)	437x508x647
Packaging dimensions (WxDxH mm)	650x680x880
Loading quantities 20'/40'/40'HQ	48/108/162

## CERTIFICATION

CE RoHS

GAS  
**R290**

50 mm

**3** +25°C/60RH

LED

LOCK

## DETAILS



Opening door alarm/High temperature alarm



Blue backlit main switch



Stainless steel top



Shelf with small distance between the line and bottom shelf fits as standard



Evaporator with anti-corrosion treatment



Inner LED light



External cylindrical handle in stainless steel (Steel color for X Version)

## PRODUCT DIMENSIONS

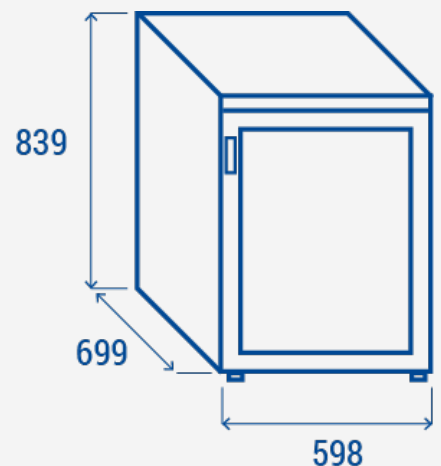

**RIGHTWAY ASIA**  
We make the world a cooler place