

DRINKS | Chestcooler

COOLER ▶ CAN COOLER



GENERAL FEATURES

- 80 Lt. Cans cooler with glass top
- External in black coated plate, grey painted steel internally
- Static cooling with fan assisted cooling
- Manual Defrost
- Defrost water drain
- Foaming Agent Cyclopentane (60mm per side)
- Handle along door profile
- Single tempered safety glass
- Basket included (N.1 Pcs)
- Basket capacity: 66 cans
- N.4 Castor (N.1 in the front with brake)
- Energy efficiency class: B

TECHNICAL SPECIFICATIONS

Capacity	77 L
Temperature	M2 (-1°C-+7°C)
Consumption	0.67 kWh/24h
Rated Power	85 W
Noise level	36 dB(A)
Net Weight	29 Kg
Gross Weight	34 Kg
External Dimensions (WxDxH mm)	569x569x849
Internal Dimensions (WxDxH mm)	458x458x490
Packaging dimensions (WxDxH mm)	585x585x880
Loading quantities 20'/40'/40"HQ	80/160/240

CERTIFICATION

CE RoHS



HP 80

CUSTOMIZATION AVAILABLE
PERSONALIZZAZIONE DISPONIBILE

+0° | +10°

60 mm | M2 | -1°C | +7°C | B ENERGY CLASS | 3 | +25°C/60RH | FILE NOT FOUND | GAS R600a

DETAILS

Tempered glass top | Basket included | Inner assistance fan | Wheels for easy positioning

PRODUCT DIMENSIONS

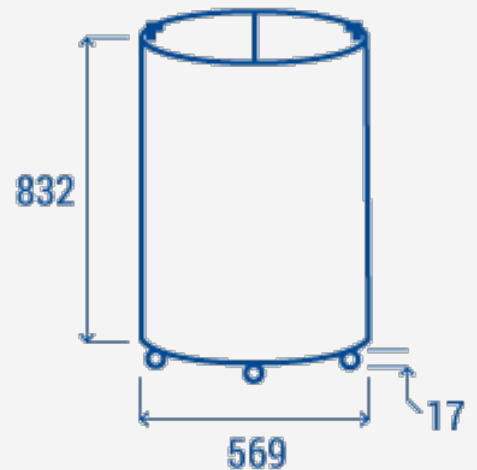

RIGHTWAY ASIA
We make the world a cooler place