

DRINKS | Minibars

THERMOELECTRIC MINIBAR

MB 42



40 mm

GAS
R600a

C
ENERGY CLASS

N +16°C/+32°C



DETAILS



Lock fitted as standard



PCB Thermostat with knob for temperature regulation



Handle along door profile



Inner door rack



GENERAL FEATURES

- 40 Lt. Absorption Minibar •
- Absorption cooling with R600a •
- Silent operation •
- Low vibrations •
- Low maintenance •
- Foaming Agent Cyclopentane (40mm per side - CFC Free) •
- Mechanical thermostat •
- Interior LED light •
- Lock fitted as standard •
- Door rack •
- Removable Gasket •
- Adjustable shelves: 1 Pcs •
- Handle along door profile •
- N.4 Adjustable feet •
- Energy efficiency class: C •

TECHNICAL SPECIFICATIONS

Capacity	40 L
Temperature	+6° ~ +12°C
Consumption	0.128 kWh/24h
Rated Power	60 W
Noise level	26 dB(A)
Net Weight	9 Kg
Gross Weight	10 Kg
External Dimensions (WxDxH mm)	430x424x515
Internal Dimensions (WxDxH mm)	356x266x410
Packaging dimensions (WxDxH mm)	460x440x530
Loading quantities 20'/40'/40'HQ	260/540/672

CERTIFICATION

CE  RoHS

PRODUCT DIMENSIONS

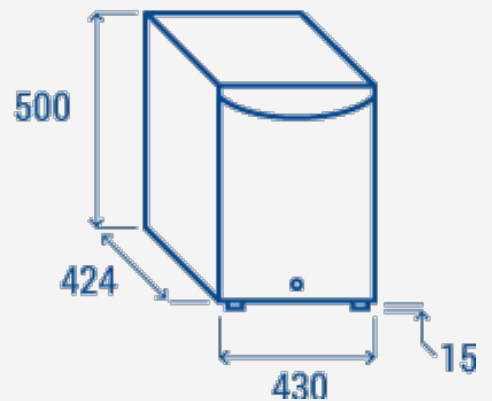

RIGHTWAY ASIA
We make the world a cooler place