

# DRINKS | Minibars

ABSORPTION MINIBAR



# MB 50









## DETAILS

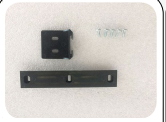

Inner door rack



Sliding door kit



Inner LED light



Lock fitted as standard



Handle along door profile

## GENERAL FEATURES

- 50 Lt. Absorption Minibar •
- Absorption cooling with R717 (ammonia) •
- Silent operation •
- Low maintenance •
- Foaming Agent Cyclopentane (45mm per side) •
- Interior LED light •
- Removable Gasket •
- Reversible door •
- Lock fitted as standard •
- Door rack •
- Adjustable shelves: 3 Pcs •
- Sliding door kit predisposition •
- Adjustable feet •
- Energy efficiency class: G •

## TECHNICAL SPECIFICATIONS

Capacity	<b>50 L</b>
Temperature	<b>+5° ~ +12°C</b>
Consumption	<b>0.53 kWh/24h</b>
Rated Power	<b>50 W</b>
Noise level	<b>0 dB(A)</b>
Net Weight	<b>20 Kg</b>
Gross Weight	<b>23 Kg</b>
External Dimensions (WxDxH mm)	<b>402x464x666</b>
Internal Dimensions (WxDxH mm)	<b>312x250x565</b>
Packaging dimensions (WxDxH mm)	<b>450x500x720</b>
Loading quantities 20'/40'/40"HQ	<b>171/360/438</b>

## PRODUCT DIMENSIONS

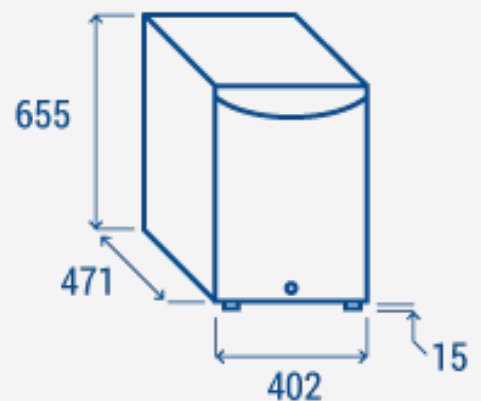

## CERTIFICATION

CE  RoHS



**RIGHTWAY ASIA**  
We make the world a cooler place