

INOX | Saladette

SALADETTE ▶ GN1/1 ▶ SANDWICH TOP



GENERAL FEATURES

- GN1/1 Refrigerated saladette (SANDWICH TOP)
- Stainless Steel exterior and interior
- Static cooling with fan assisted cooling
- Automatic compressor cycle defrost
- Foaming Agent Cyclopentane (35mm per side)
- Digital Thermostat
- Independent main switch
- Foamed door handle
- Easy removable condenser filter
- Separated plastic water tray
- Front panel tilted holes for better air circulation
- Adjustable shelves GN1/1: 2 Pcs
- Removable Gasket
- N.2 Adjustable feet + N.2 Rollers at the back
- Holder spacer for GN pans (included)
- Stainless steel LID top
- Energy efficiency class: -

TECHNICAL SPECIFICATIONS

Capacity	247 L
Temperature	+2° - +10°C
Consumption	3.39 kWh/24h
Rated Power	143 W
Noise level	48 dB(A)
Net Weight	85 Kg
Gross Weight	99 Kg
External Dimensions (WxDxH mm)	900x700x990
Internal Dimensions (WxDxH mm)	830x595x455
Packaging dimensions (WxDxH mm)	930x730x1130
Loading quantities 20'/40'/40'HQ	36/72/72

CERTIFICATION

CE RoHS

PS 200



Water

Static cooling

GAS
R290

35 mm

4
CLIMATIC CLASS

36°C

DETAILS

All shelves mounted with anti-tipping system

Inner assistance fan

PRODUCT DIMENSIONS

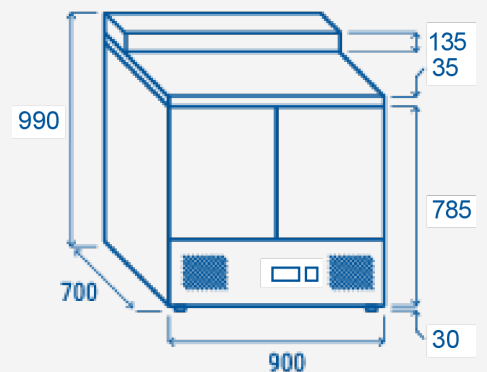

RIGHTWAY ASIA
We make the world a cooler place