

# INOX | Saladette

SALADETTE ▶ GN1/1 ▶ PIZZA TOP



## GENERAL FEATURES

- GN1/1 Refrigerated saladette (PIZZA TOP)
- Stainless Steel exterior and interior
- Granite top (WHITE Coor)
- Static cooling with fan assisted cooling
- Automatic compressor cycle defrost
- Foaming Agent Cyclopentane (35mm per side)
- Digital Thermostat
- Independent main switch
- Foamed door handle
- Easy removable condenser filter
- Separated plastic water tray
- Front panel tilted holes for better air circulation
- Adjustable shelves GN1/1: 2 Pcs
- Removable Gasket
- N.2 Adjustable feet + N.2 Rollers at the back
- Holder spacer for GN pans (included)
- Energy efficiency class: -

## TECHNICAL SPECIFICATIONS

Capacity	<b>247 L</b>
Temperature	<b>+2° - +10°C</b>
Consumption	<b>3.39 kWh/24h</b>
Rated Power	<b>143 W</b>
Noise level	<b>48 dB(A)</b>
Net Weight	<b>92 Kg</b>
Gross Weight	<b>114 Kg</b>
External Dimensions (WxDxH mm)	<b>900x700x1070</b>
Internal Dimensions (WxDxH mm)	<b>830x595x455</b>
Packaging dimensions (WxDxH mm)	<b>930x730x1205</b>
Loading quantities 20'/40'/40'HQ	<b>36/36/72</b>

## CERTIFICATION

CE RoHS



# PS 900



## DETAILS



## PRODUCT DIMENSIONS

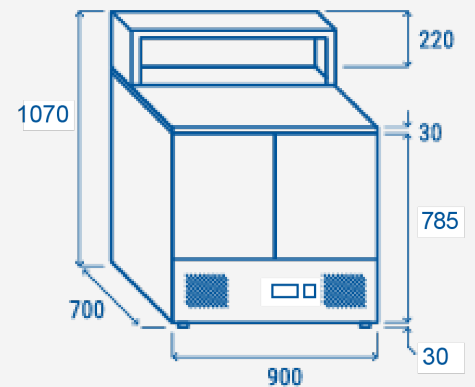

**RIGHTWAY ASIA**  
We make the world a cooler place