

INOX | Upright Cabinets

BAKERY REFRIGERATED CABINETS ▶ VENTILATED ▶ CHILLER



GENERAL FEATURES

- EURONORM refrigerated upright cabinet
- Stainless Steel exterior and interior
- Ventilated Cooling
- Automatic defrost with electric heater
- Evaporator with anti-corrosion treatment
- Engine made with "Cassette system"
- Foaming Agent Cyclopentane (75mm per side)
- Digital Thermostat
- White backlit main switch
- Opening door alarm
- Removable Gasket
- LED light and lock fitted as standard
- Door with self closing door
- Set of 20 slides for bakery tray 600X400
- N.4 S/S Adjustable feet - (Lockable castor as Optional)
- Energy efficiency class: D

TECHNICAL SPECIFICATIONS

Capacity	1300 L
Temperature	+2° - +8°C
Consumption	4.301 kWh/24h
Rated Power	350 W
Noise level	50 dB(A)
Net Weight	189 Kg
Gross Weight	212 Kg
External Dimensions (WxDxH mm)	1400x820x2050
Internal Dimensions (WxDxH mm)	1250x685x1435
Packaging dimensions (WxDxH mm)	1440x860x2080
Loading quantities 20'/40'/40'HQ	10/21/21

CERTIFICATION

CE RoHS



QPC 1640

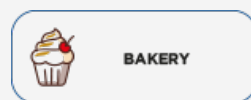

		GAS R290	 75 mm	4 CLIMATIC CLASS	 38°C

DETAILS

The items can be supplied either with adjustable feet or lockable castor	Euronorm 600x400mm set of guides (10 Layer for each door)	Curved edge for easy cleaning
Evaporator with anti-corrosion treatment	Digital control and white backlit main switch	

PRODUCT DIMENSIONS

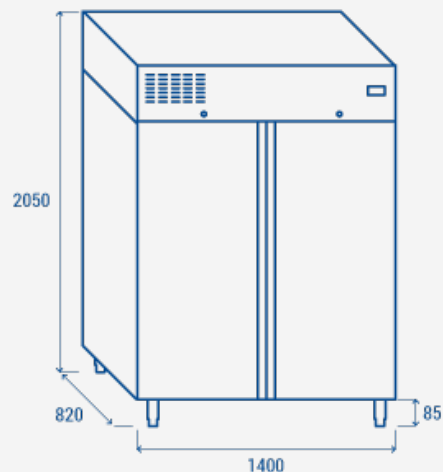

RIGHTWAY ASIA
We make the world a cooler place