

INOX | Upright Cabinets

BAKERY REFRIGERATED CABINETS ▶ VENTILATED ▶ CHILLER

QPC 740



-
-
- GAS
R290
- 75 mm
- 4**
CLIMATIC CLASS
- 38°C
- LED
-
-

DETAILS



The items can be supplied either with adjustable feet or lockable castor



Euronorm 600x400mm set of guides (10 Layer for each door)



Curved edge for easy cleaning



Evaporator with anti-corrosion treatment



Digital control and white backlit main switch



GENERAL FEATURES

- EURONORM refrigerated upright cabinet •
- Stainless Steel exterior and interior •
- Ventilated Cooling •
- Automatic defrost with electric heater •
- Engine made with "Cassette system" •
- Evaporator with anti-corrosion treatment •
- Foaming Agent Cyclopentane (75mm per side) •
- Digital Thermostat •
- White backlit main switch •
- Opening door alarm •
- Removable Gasket •
- LED light and lock fitted as standard •
- Door: Self closing and reversible door fitted as standard •
- Set of 10 slides for bakery tray 600X400 •
- N.4 S/S Adjustable feet - (Lockable castor as Optional) •
- Energy efficiency class: D •

TECHNICAL SPECIFICATIONS

Capacity	550 L
Temperature	+2° - +8°C
Consumption	2.701 kWh/24h
Rated Power	156 W
Noise level	49 dB(A)
Net Weight	120 Kg
Gross Weight	147 Kg
External Dimensions (WxDxH mm)	700x820x2050
Internal Dimensions (WxDxH mm)	550x685x1435
Packaging dimensions (WxDxH mm)	740x860x2170
Loading quantities 20'/40'/40'HQ	20/41/41

CERTIFICATION

CE RoHS

PRODUCT DIMENSIONS

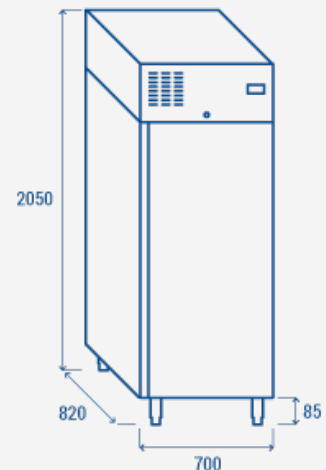

RIGHTWAY ASIA
We make the world a cooler place