

INOX | Upright Cabinets

REFRIGERATED CABINETS ▶ GN2/1-NO FROST ▶ CHILLER

QR 12-5A



GENERAL FEATURES

- GN2/1 Refrigerated upright cabinet (CLASS A)
- Stainless Steel exterior and interior
- Plastic thermal-braker anti-condensation as chamber body frame
- Ventilated Cooling
- Inverter compressor
- Evaporator with anti-corrosion treatment
- Hot gas defrost system
- Foaming Agent Cyclopentane (80mm)
- Curved edge for easy cleaning
- Digital Thermostat
- White backlit main switch
- LED light and lock fitted as standard
- Removable Gasket
- Door with self closing door
- Foamed door handle
- Adjustable shelves GN2/1: 6 + 2 + 4 middle
- N.4 S/S Adjustable feet - (Lockable castor as Optional)
- Energy efficiency class: A

TECHNICAL SPECIFICATIONS

Capacity	1255 L
Temperature	-2° - +8°C
Consumption	1.92 kWh/24h
Rated Power	191W
Noise level	50 dB(A)
Net Weight	165 Kg
Gross Weight	187 Kg
External Dimensions (WxDxH mm)	1400x834x2045
Internal Dimensions (WxDxH mm)	1234x685x1485
Packaging dimensions (WxDxH mm)	1420x850x2110
Loading quantities 20'/40'/40'HQ	10/21/21

CERTIFICATION

CE RoHS

ENERGY SAVING

TROPICALIZED UPRIGHT

GAS
R600a

80 mm

A
ENERGY CLASS

5
CLIMATIC CLASS

40°C

LED

LOCK

ANTI-CONDENSATION

ANTI-CORROSION TREATMENT

DETAILS

The items can be supplied either with adjustable feet or lockable castor

Inverter compressor

Evaporator with anti-corrosion treatment

Inner stainless steel waved guides

Anti-condensation "thermal-braker" on door frame

Lock fitted as standard

Digital control and white backlit main switch

Inner LED light

Cabinet suitable for GN2/1 pans

PRODUCT DIMENSIONS

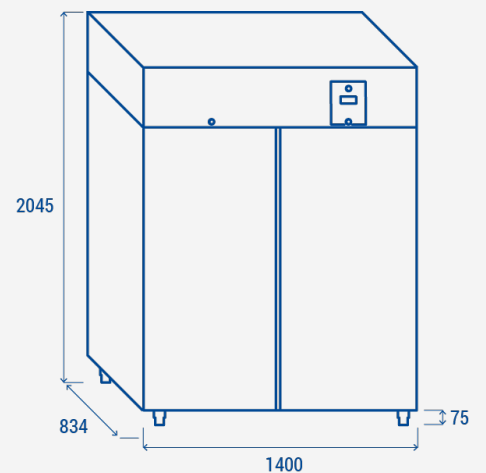

RIGHTWAY ASIA
We make the world a cooler place