

INOX | Upright Cabinets

REFRIGERATED CABINETS ▶ GN2/1-NO FROST ▶ CHILLER

QR 14



GENERAL FEATURES

- GN2/1 Refrigerated upright cabinet (CLASS B)
- Stainless Steel exterior and interior
- Plastic thermal-braker anti-condensation as chamber body frame
- Inner with embossed rear shelf stopper and wave for easy cleaning
- Ventilated Cooling
- Evaporator with anti-corrosion treatment
- Automatic defrost with electric heater
- Foaming Agent Cyclopentane (85mm)
- Digital thermostat with "opening door" and "High temperature" alarm
- Removable Gasket
- LED light and lock fitted as standard
- Door with self closing door
- Adjustable shelves GN2/1: 6 + 2 + 3 middle
- N.4 S/S Adjustable feet - (Lockable castor as Optional)
- Energy efficiency class: B

TECHNICAL SPECIFICATIONS

Capacity	1105 L
Temperature	-2°C ~ +8°C
Consumption	2.55 kWh/24h
Rated Power	240 W
Noise level	62 dB(A)
Net Weight	234 Kg
Gross Weight	265 Kg
External Dimensions (WxDxH mm)	1430x918x2085
Internal Dimensions (WxDxH mm)	1260x665x1390
Packaging dimensions (WxDxH mm)	1450x930x2170
Loading quantities 20'/40'/40"HQ	7/16/16

CERTIFICATION

CE RoHS

GAS
R290

85 mm

B
ENERGY CLASS

4
CLIMATIC CLASS

38°C

LED

DETAILS

The items can be supplied either with adjustable feet or lockable castor

Top horizontal LED light

Embossed rear shelf-stopper

Inner stainless steel waved guides

"Door opening and High temperature alarm" as standard

Bottom hole for easily clean and dry the item

Evaporator with anti-corrosion treatment

Main switch and digital thermostat fitted as standard

PRODUCT DIMENSIONS

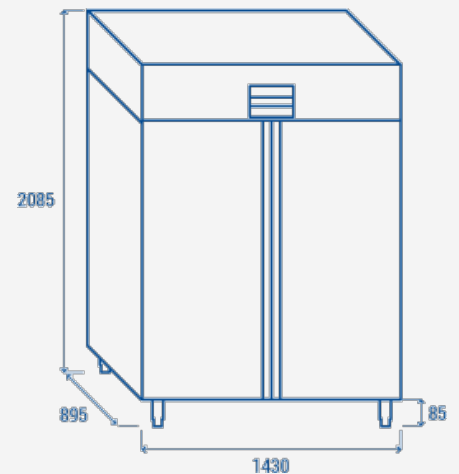

RIGHTWAY ASIA
We make the world a cooler place