

INOX | Upright Cabinets

REFRIGERATED CABINETS ▶ GN2/1-NO FROST ▶ CHILLER

QRG 12



DETAILS

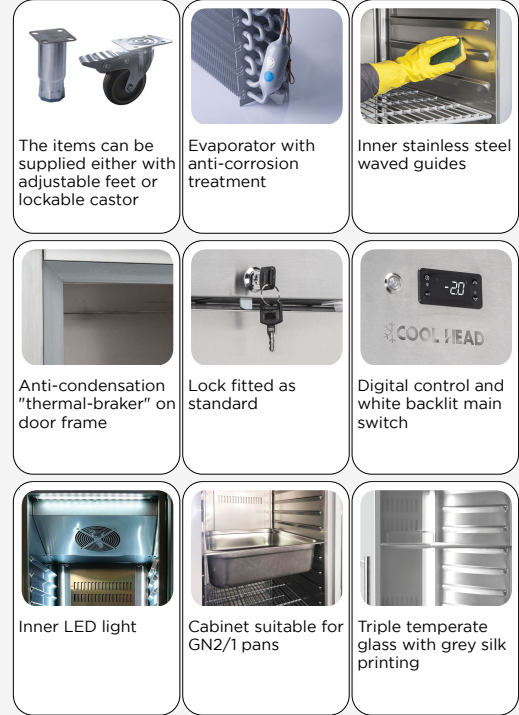

GENERAL FEATURES

- GN2/1 Refrigerated upright cabinet (GLASS DOOR) •
- Stainless Steel exterior and interior •
- Plastic thermal-braker anti-condensation as chamber body frame •
- Ventilated Cooling •
- Evaporator with anti-corrosion treatment •
- Hot gas defrost system •
- Foaming Agent Cyclopentane (80mm) •
- Curved edge for easy cleaning •
- Digital Thermostat •
- White backlit main switch •
- LED light and lock fitted as standard •
- Removable Gasket •
- Door with self closing door •
- Foamed door handle •
- Adjustable shelves GN2/1: 6 + 2 •
- N.4 S/S Adjustable feet - (Lockable castor as Optional) •
- Energy efficiency class: E •

TECHNICAL SPECIFICATIONS

Capacity	1255 L
Temperature	+3° - +10°C
Consumption	4.512 kWh/24h
Rated Power	368 W
Noise level	50 dB(A)
Net Weight	180.60 Kg
Gross Weight	215.00 Kg
External Dimensions (WxDxH mm)	1400x891x2045
Internal Dimensions (WxDxH mm)	1234x685x1485
Packaging dimensions (WxDxH mm)	1420x860x2110
Loading quantities 20'/40'/40'HQ	10/21/21

CERTIFICATION



PRODUCT DIMENSIONS

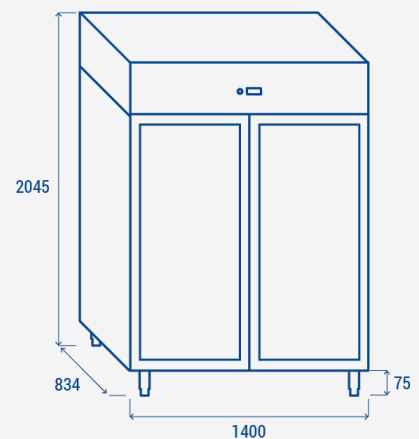

RIGHTWAY ASIA
We make the world a cooler place