

INOX | Upright Cabinets

REFRIGERATED CABINETS ▶ GN2/1-NO FROST ▶ CHILLER



GENERAL FEATURES

- GN2/1 Refrigerated upright cabinet (GLASS DOOR)
- Stainless Steel exterior and interior
- Plastic thermal-braker anti-condensation as chamber body frame
- Ventilated Cooling
- Evaporator with anti-corrosion treatment
- Hot gas defrost system
- Foaming Agent Cyclopentane (80mm)
- Curved edge for easy cleaning
- Digital Thermostat
- White backlit main switch
- LED light and lock fitted as standard
- Removable Gasket
- Door with self closing (Not reversable)
- Foamed door handle
- Adjustable shelves GN2/1: 3 + 1
- N.4 S/S Adjustable feet - (Lockable castor as Optional)
- Energy efficiency class: E

TECHNICAL SPECIFICATIONS

Capacity	546 L
Temperature	+3° - +10°C
Consumption	2.855 kWh/24h
Rated Power	311 W
Noise level	50 dB(A)
Net Weight	114.50 Kg
Gross Weight	133.00 Kg
External Dimensions (WxDxH mm)	700x891x2045
Internal Dimensions (WxDxH mm)	534x685x1485
Packaging dimensions (WxDxH mm)	720x860x2110
Loading quantities 20'/40'/40'HQ	21/43/43

CERTIFICATION

CE RoHS

QRG 6



DETAILS

<p>The items can be supplied either with adjustable feet or lockable castor</p>	<p>Evaporator with anti-corrosion treatment</p>	<p>Inner stainless steel waved guides</p>
<p>Anti-condensation "thermal-braker" on door frame</p>	<p>Lock fitted as standard</p>	<p>Digital control and white backlit main switch</p>
<p>Inner LED light</p>	<p>Cabinet suitable for GN2/1 pans</p>	<p>Triple temperate glass with grey silk printing</p>

PRODUCT DIMENSIONS

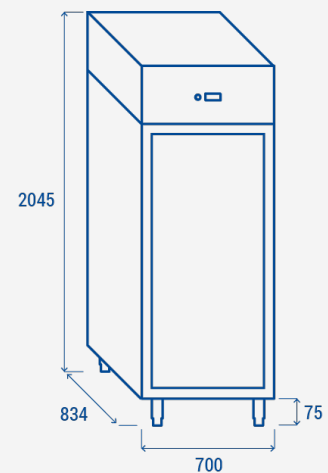

RIGHTWAY ASIA
We make the world a cooler place