

# INOX | Upright Cabinets

REFRIGERATED CABINETS ▶ GN2/1-NO FROST ▶ CHILLER

QRM 6



## GENERAL FEATURES

- GN2/1 Refrigerated upright cabinet (SPLIT DOOR) •
- Stainless Steel exterior and interior •
- Plastic thermal-braker anti-condensation as chamber body frame •
- Ventilated Cooling •
- Evaporator with anti-corrosion treatment •
- Hot gas defrost system •
- Foaming Agent Cyclopentane (80mm) •
- Curved edge for easy cleaning •
- Digital Thermostat •
- White backlit main switch •
- LED light and lock fitted as standard •
- Removable Gasket •
- Door: Self closing and reversible door fitted as standard •
- Foamed door handle •
- Adjustable shelves GN2/1: 3 + 1 •
- N.4 S/S Adjustable feet - (Lockable castor as Optional) •
- Energy efficiency class: C •

## TECHNICAL SPECIFICATIONS

Capacity	<b>546 L</b>
Temperature	<b>-2° - +8°C</b>
Consumption	<b>1.699 kWh/24h</b>
Rated Power	<b>216 W</b>
Noise level	<b>50 dB(A)</b>
Net Weight	<b>108.00 Kg</b>
Gross Weight	<b>121.00 Kg</b>
External Dimensions (WxDxH mm)	<b>700x838x2045</b>
Internal Dimensions (WxDxH mm)	<b>534x685x1485</b>
Packaging dimensions (WxDxH mm)	<b>720x860x2110</b>
Loading quantities 20'/40'/40'HQ	<b>21/42/42</b>

## CERTIFICATION

CE RoHS



## DETAILS



## PRODUCT DIMENSIONS

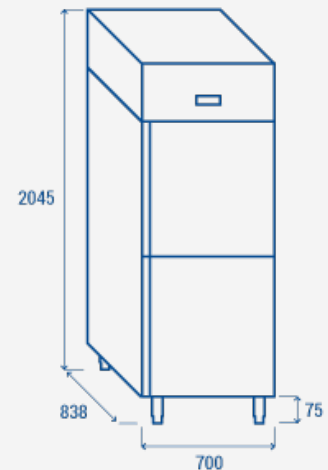

**RIGHTWAY ASIA**  
We make the world a cooler place