

DISPLAY | Countertop Displays

REFRIGERATED COUNTERTOP SHOWCASES



GENERAL FEATURES

- 100 Lt. BLACK Refrigerated countertop showcase
- Curve glass with black frame and stainless steel basement
- Ventilated Cooling
- Automatic compressor cycle defrost
- Digital display control
- Interior LED light
- Anti-condensation double layer glass
- Rear sliding doors
- Adjustable chromed shelves (N.2 Pcs)
- N.4 fix support assembled under the basement
- Energy efficiency class: B

TECHNICAL SPECIFICATIONS

| | |
|----------------------------------|--------------------------|
| Capacity | 100 L |
| Temperature | H1 (+1°C-- +10°C) |
| Consumption | 2.498 kWh/24h |
| Rated Power | 160 W |
| Noise level | 51 dB(A) |
| Net Weight | 39.1 Kg |
| Gross Weight | 47 Kg |
| External Dimensions (WxDxH mm) | 682x450x675 |
| Internal Dimensions (WxDxH mm) | 622x410x417 |
| Packaging dimensions (WxDxH mm) | 756x524x880 |
| Loading quantities 20'/40'/40"HQ | 66/136/136 |

CERTIFICATION

CE RoHS



RC 100B

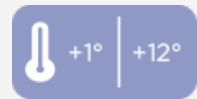

GAS **R600a** | H1 | +1°C | +10°C | ENERGY CLASS **B** | 4 | +30°C/55RH

LED | | |

DETAILS

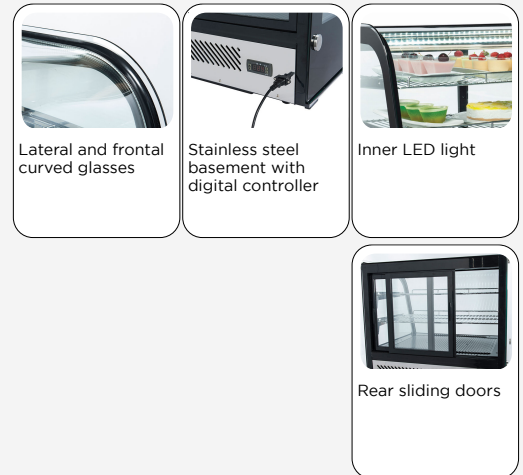

PRODUCT DIMENSIONS

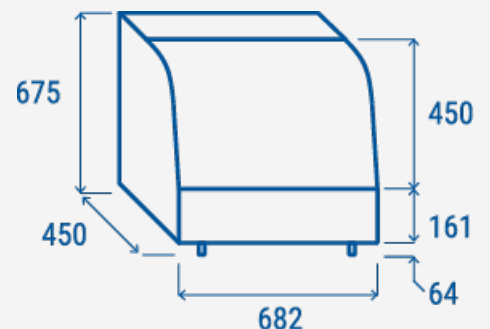

RIGHTWAY ASIA
We make the world a cooler place