

# DISPLAY | Countertop Displays

REFRIGERATED COUNTERTOP SHOWCASES



## GENERAL FEATURES

- 100 Lt. WHITE Refrigerated countertop showcase
- Curve glass with white frame and stainless steel basement
- Ventilated Cooling
- Automatic compressor cycle defrost
- Digital display control
- Interior LED light
- Anti-condensation double layer glass
- Rear sliding doors
- Adjustable chromed shelves (N.2 Pcs)
- N.4 fix support assembled under the basement
- Energy efficiency class: B

## TECHNICAL SPECIFICATIONS

Capacity	<b>100 L</b>
Temperature	<b>H1 (+1°C-- +10°C)</b>
Consumption	<b>2.498 kWh/24h</b>
Rated Power	<b>160 W</b>
Noise level	<b>51 dB(A)</b>
Net Weight	<b>39.1 Kg</b>
Gross Weight	<b>47 Kg</b>
External Dimensions (WxDxH mm)	<b>682x450x675</b>
Internal Dimensions (WxDxH mm)	<b>622x410x417</b>
Packaging dimensions (WxDxH mm)	<b>756x524x880</b>
Loading quantities 20'/40'/40"HQ	<b>66/136/136</b>

## CERTIFICATION



CE  RoHS

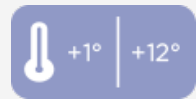

# RC 100W



GAS **R600a** | H1 | +1°C | +10°C | ENERGY CLASS **B** | 4 | +30°C/55RH

LED |  |  | 

## DETAILS

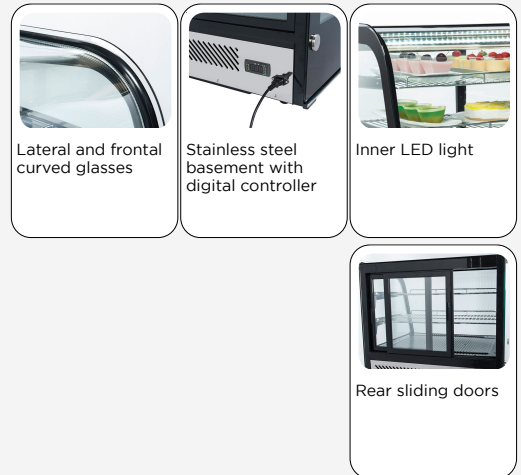

## PRODUCT DIMENSIONS

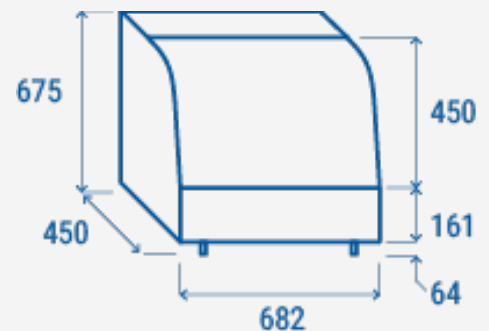

**RIGHTWAY ASIA**  
We make the world a cooler place