

# DISPLAY | Countertop Displays

REFRIGERATED COUNTERTOP SHOWCASES

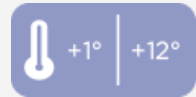

# RC 120



GAS <b>R600a</b>	M2 -1°C +7°C	<b>B</b> ENERGY CLASS	4 +30°C/55RH
LED			

## DETAILS



Lateral and frontal curved glasses



Stainless steel basement with digital controller



Inner LED light



Rear sliding doors

## GENERAL FEATURES

- 120 Lt. Refrigerated countertop showcase
- Curve glass with black frame and stainless steel basement
- Ventilated Cooling
- Automatic compressor cycle defrost
- Digital display control
- Interior LED light
- Anti-condensation double layer glass
- Rear sliding doors
- Adjustable chromed shelves (N.2 Pcs)
- N.4 fix support assembled under the basement
- Energy efficiency class: B

## TECHNICAL SPECIFICATIONS

Capacity	<b>120 L</b>
Temperature	<b>M2 (-1°C-+7°C)</b>
Consumption	<b>3.125 kWh/24h</b>
Rated Power	<b>230 W</b>
Noise level	<b>52 dB(A)</b>
Net Weight	<b>64 Kg</b>
Gross Weight	<b>71 Kg</b>
External Dimensions (WxDxH mm)	<b>695x570x685</b>
Internal Dimensions (WxDxH mm)	<b>665x485x410</b>
Packaging dimensions (WxDxH mm)	<b>773x627x855</b>
Loading quantities 20'/40'/40"HQ	<b>81/162/162</b>

## PRODUCT DIMENSIONS

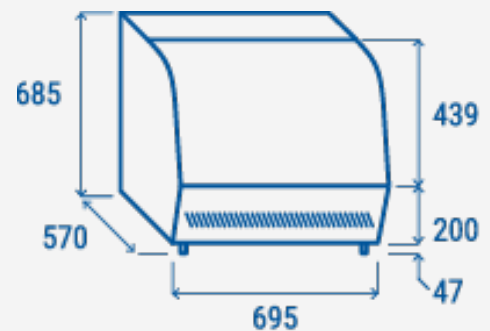

## CERTIFICATION



**RIGHTWAY ASIA**  
We make the world a cooler place