

DISPLAY | Countertop Displays

REFRIGERATED SHOWCASES UPRIGHT ▶ BLACK



RC 58B



GAS R600a	M2 -1°C +7°C	B ENERGY CLASS	4 +30°C/55RH

DETAILS

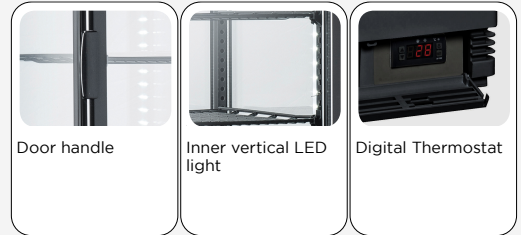

GENERAL FEATURES

- 58 Lt. Upright refrigerated showcase (Black Color)
- Flat glass with black frame and plastic basement
- Ventilated Cooling
- Automatic compressor cycle defrost
- Digital display control
- Interior LED light
- Toughened safety glass
- Adjustable shelves (N.2 shelf)
- N.4 fix support assembled under the basement
- Energy efficiency class: B

TECHNICAL SPECIFICATIONS

Capacity	58 L
Temperature	M2 (-1°C-+7°C)
Consumption	2.778 kWh/24h
Rated Power	180 W
Noise level	42 dB(A)
Net Weight	30 Kg
Gross Weight	37 Kg
External Dimensions (WxDxH mm)	428x386x810
Internal Dimensions (WxDxH mm)	400x370x450
Packaging dimensions (WxDxH mm)	475x432x1008
Loading quantities 20'/40'/40"HQ	126/252/378

PRODUCT DIMENSIONS

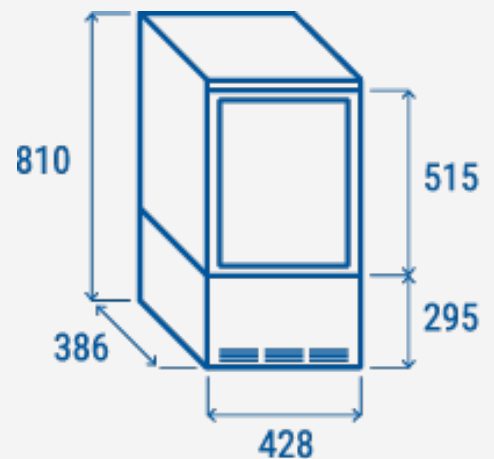

CERTIFICATION



RIGHTWAY ASIA
We make the world a cooler place