

DISPLAY | Countertop Displays

REFRIGERATED SHOWCASES UPRIGHT ▶ INOX

RC 769



GAS R290	M2 -1°C +7°C	C ENERGY CLASS	4 +30°C/55RH
LED			

DETAILS



GENERAL FEATURES

- 100 Lt. Self service 4 sides glasses cabinet
- Flat glass with steel frame and basement
- Ventilated Cooling
- Automatic compressor cycle defrost
- Digital display control
- Interior LED light
- Anti-condensation double layer glass
- Rear sliding doors
- Adjustable chromed shelves (N.2 Pcs)
- N.4 Adjustable feet
- Energy efficiency class: C

TECHNICAL SPECIFICATIONS

Capacity	101 L
Temperature	M2 (-1°C-+7°C)
Consumption	4.888 kWh/24h
Rated Power	350 W
Noise level	50.4 dB(A)
Net Weight	65 Kg
Gross Weight	78 Kg
External Dimensions (WxDxH mm)	805x438x770
Internal Dimensions (WxDxH mm)	758x366x438
Packaging dimensions (WxDxH mm)	894x532x920
Loading quantities 20'/40'/40"HQ	44/92/92

PRODUCT DIMENSIONS

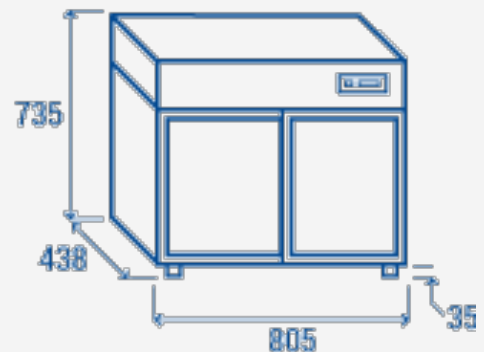

CERTIFICATION

CE RoHS



RIGHTWAY ASIA
We make the world a cooler place