

DRINKS | Countertop Cabinets

DRINK COOLER ► UPRIGHT COOLERS

RCF 60

CUSTOMIZATION AVAILABLE
PERSONALIZZAZIONE DISPONIBILE

+0° | +10°

40 mm

K1
+0°C
+7°C

C
ENERGY CLASS

CC1

+25°C
60RH

Key icon

Door icon

Water icon

Compressor icon

Fan icon

GAS
R600a

LED



DETAILS



Inner LED light and assistance fan



Lock fitted as standard



Independent light switches for inner light



Foamed door handle

GENERAL FEATURES

- 60 Lt. Upright drink cooler
- External in black coated plate, black aluminium internally
- Roll-bond evaporator system with fan assisted cooling
- Manual Defrost
- Foaming Agent Cyclopentane (40mm per side)
- Removable Gasket
- Independent switch for internal light
- Double layer safety tempered glass
- Self Closing Door
- Lock fitted as standard
- Adjustable shelves (Black Color): 3 Pcs
- N.4 Adjustable feet
- Energy efficiency class: C

TECHNICAL SPECIFICATIONS

Capacity	67 L
Temperature	K1 (0°C-+7°C)
Consumption	0.558 kWh/24h
Rated Power	80 W
Noise level	45 dB
Net Weight	32.5 Kg
Gross Weight	34.5 Kg
External Dimensions (WxDxH mm)	432x496x672
Internal Dimensions (WxDxH mm)	356x368x557
Packaging dimensions (WxDxH mm)	486x552x705
Loading quantities 20'/40'/40"HQ	144/288/288

CERTIFICATION

CE RoHS

PRODUCT DIMENSIONS

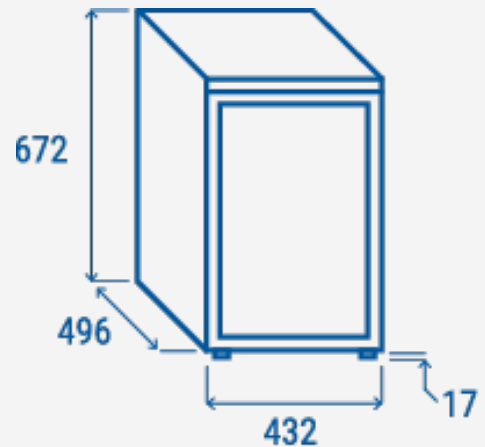

RIGHTWAY ASIA
We make the world a cooler place