

# DRINKS | Drink Cabinets

DRINK COOLER ► UPRIGHT COOLERS

# RCF 85

**CUSTOMIZATION AVAILABLE**  
PERSONALIZZAZIONE DISPONIBILE

+4° | +10°

45 mm | K4 | +1°C | +9°C | ENERGY CLASS C | CC2 | +32°C | 65RH | LED | Lock | Fan | R600a GAS

## DETAILS



## GENERAL FEATURES

- 85 Lt. Upright drink cooler
- External in white coated plate, white thermoformed internally
- Roll-bond evaporator system with fan assisted cooling
- Manual Defrost
- Foaming Agent Cyclopentane (45mm per side)
- Removable Gasket
- Independent switch for internal light
- Double layer safety tempered glass
- Digital thermometer
- Reversible door
- Lock fitted as standard
- Adjustable shelves (White Color): 3 Pcs
- N.4 Adjustable feet
- Energy efficiency class: C

## TECHNICAL SPECIFICATIONS

Capacity	85 L
Temperature	K4 (+1°C-+9°C)
Consumption	2.68 kWh/24h
Rated Power	65 W
Noise level	46 dB(A)
Net Weight	35 Kg
Gross Weight	38 Kg
External Dimensions (WxDxH mm)	505x590x780
Internal Dimensions (WxDxH mm)	410x395x625
Packaging dimensions (WxDxH mm)	580x620x810
Loading quantities 20'/40'/40"HQ	72/158/228

## PRODUCT DIMENSIONS

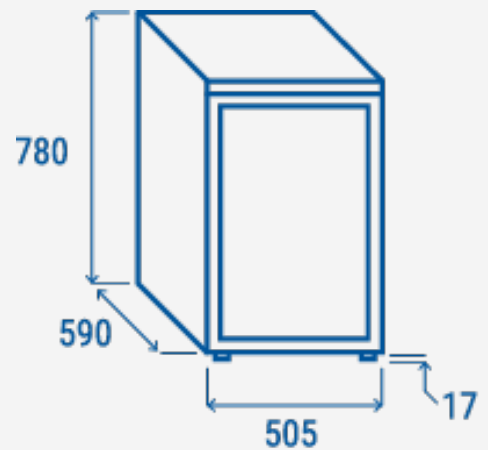

## CERTIFICATION

CE RoHS



**RIGHTWAY ASIA**  
We make the world a cooler place