

DRINKS | Minibars

ABSORPTION MINIBAR ▶ GLASS DOOR



RCG 50A











DETAILS



Inner LED light



Handle along door profile



Lock fitted as standard

GENERAL FEATURES

- 50 Lt. Absorption upright drink cooler
- Absorption cooling with R717 (ammonia)
- Silent operation
- Low maintenance
- Foaming Agent Cyclopentane (45mm per side)
- Interior LED light
- Removable Gasket
- Triple safety tempered glass with Low-e (Low emissivity glasses)
- Reversible door
- Lock fitted as standard
- Adjustable shelves: 3
- Handle along door profile
- Adjustable feet
- Energy efficiency class: G

TECHNICAL SPECIFICATIONS

Capacity	50 L
Temperature	+7° ~ +14°C
Consumption	kWh/24h
Rated Power	90 W
Noise level	22 dB(A)
Net Weight	23 Kg
Gross Weight	26 Kg
External Dimensions (WxDxH mm)	402x450x670
Internal Dimensions (WxDxH mm)	312x250x565
Packaging dimensions (WxDxH mm)	450x490x720
Loading quantities 20'/40'/40"HQ	171/360/438

PRODUCT DIMENSIONS

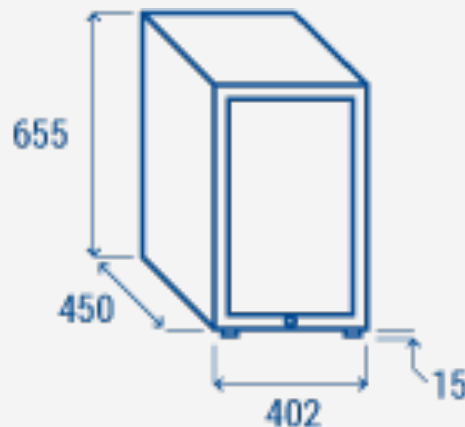

CERTIFICATION

CE  RoHS



RIGHTWAY ASIA
We make the world a cooler place