

WINE | Upright Cabinets

WINE COOLERS



RCS 88



DETAILS



GENERAL FEATURES

- 88 Lt. Wine cellar free-standing installation
- External in black coated plate, black thermoformed internally
- Roll-bond evaporator system with fan assisted cooling
- Automatic compressor cycle defrost
- Foaming Agent Cyclopentane (40mm per side)
- Mechanical thermostat
- Removable Gasket
- Interior LED light
- Double layer safety tempered glass
- Transparent glass
- Reversible door
- Adjustable chromed shelf (6 Pcs) and chromed basket (1 Pcs)
- N.4 Adjustable feet
- Energy efficiency class: G

TECHNICAL SPECIFICATIONS

Capacity	90 L
Temperature	+4° ~ +18°C
Consumption	0.38 kWh/24h
Rated Power	85 W
Noise level	40 dB(A)
Net Weight	23 Kg
Gross Weight	30 Kg
External Dimensions (WxDxH mm)	430x473x830
Internal Dimensions (WxDxH mm)	356x394x727
Packaging dimensions (WxDxH mm)	460x515x845
Loading quantities 20'/40'/40"HQ	142/300/345

PRODUCT DIMENSIONS

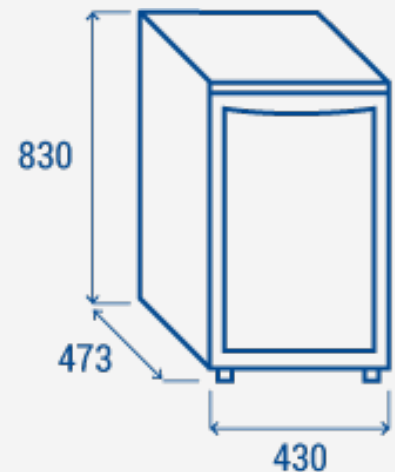

CERTIFICATION

CE RoHS



RIGHTWAY ASIA
We make the world a cooler place