

INOX | Upright Cabinets

REFRIGERATED CABINETS ▶ GN2/1-NO FROST ▶ FREEZER

RF 14

		GAS R290	 75 mm	4 CLIMATIC CLASS	 38°C

DETAILS

The items can be supplied either with adjustable feet or lockable castor	Curved edge for easy cleaning



GENERAL FEATURES

- GN2/1 Freezer upright cabinet
- Stainless Steel exterior and interior
- Plastic thermal-braker as chamber body frame (Hot pipe system)
- Ventilated Cooling
- Automatic defrost with electric heater
- Foaming Agent Cyclopentane (75mm)
- Curved edge for easy cleaning
- Digital Thermostat
- Lock and main switch fitted as standard
- Inner LED light
- Removable Gasket
- Door with self closing door
- Foamed door handle
- Adjustable shelves GN2/1: 8 pcs
- N.4 S/S Adjustable feet - (Lockable castor as Optional)
- Energy efficiency class: D

TECHNICAL SPECIFICATIONS

Capacity	1400 L
Temperature	-18° ~ -22°C
Consumption	11.2 kWh/24h
Rated Power	950 W
Noise level	53 dB(A)
Net Weight	200 Kg
Gross Weight	214 Kg
External Dimensions (WxDxH mm)	1400x880x2043
Internal Dimensions (WxDxH mm)	1253x698x1426
Packaging dimensions (WxDxH mm)	1440x900x2143
Loading quantities 20'/40'/40'HQ	N/A/16/16

CERTIFICATION

CE RoHS

PRODUCT DIMENSIONS

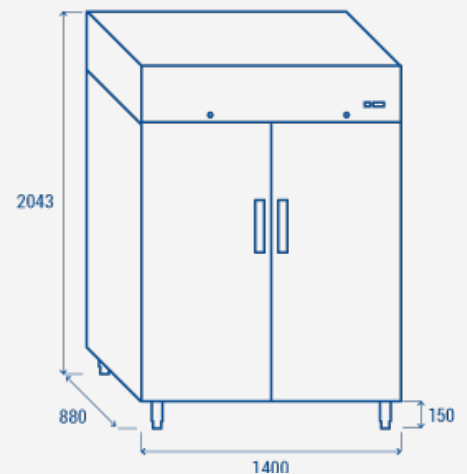

RIGHTWAY ASIA
We make the world a cooler place