

# DISPLAY | Countertop Displays

REFRIGERATED COUNTERTOP SHOWCASES

## RG 800

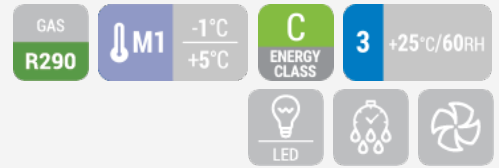

### DETAILS



### General features

- Horizontal Refrigerated countertop showcase
- Square glass with black frame and stainless steel basement
- Ventilated Cooling
- Evaporator with anti-corrosion treatment
- Automatic compressor cycle defrost
- Digital display control
- Interior LED light
- Double safety tempered glass with Low-e (Low emissivity glasses)
- Rear sliding doors
- Heated slide rails guide of the doors
- Adjustable glass shelves (N.2 Pcs)
- N.4 Adjustable feet
- Energy efficiency class: C

### Technical specifications

Capacity	<b>180 L</b>
Temperature	<b>M1 (-1°C-+5°C)</b>
Consumption	<b>6.83 kWh/24h</b>
Rated Power	<b>450 W</b>
Noise level	<b>50 dB(A)</b>
Net Weight	<b>92.00 Kg</b>
Gross Weight	<b>115.00 Kg</b>
External Dimensions (WxDxH mm)	<b>792x676x721</b>
Internal Dimensions (WxDxH mm)	<b>749x613x409</b>
Packaging dimensions (WxDxH mm)	<b>860x750x850</b>
Loading quantities 20'/40'/40"HQ	<b>36/82/123</b>

### PRODUCT DIMENSIONS

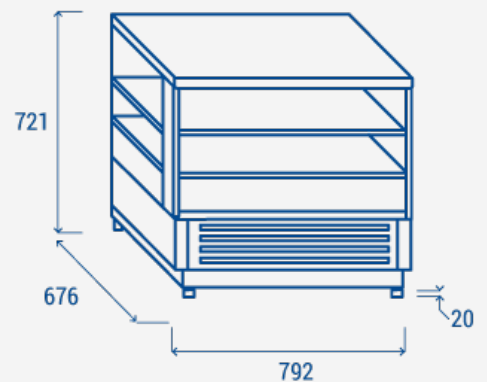

### CERTIFICATION



**RIGHTWAY ASIA**  
We make the world a cooler place