

FREEZER | Countertop Freezers

UPRIGHT FREEZER ▶ WITH CANOPY

RNG 50C

CUSTOMIZATION AVAILABLE
PERSONALIZZAZIONE DISPONIBILE



60 mm	L2 -18°C -12°C	C ENERGY CLASS	3 +25°C/60RH
LED			GAS R290

DETAILS

Lock fitted as standard	Painted aluminium door frame with integrated handle	Upright freezer with advertisement canopy
-------------------------	---	---

GENERAL FEATURES

- 50 Lt. Upright freezer with advertisement canopy
- White coated steel for internal and external side
- Static Cooling
- Manual Defrost
- Foaming Agent Cyclopentane (60mm per side)
- Removable Gasket
- Interior LED light / LED light for canopy
- Triple heated safety tempered glass
- Self Closing Door
- Painted aluminium door frame with integrated handle
- Lock fitted as standard
- Adjustable shelves: 2
- N.4 Adjustable feet
- Energy efficiency class: C

TECHNICAL SPECIFICATIONS

External Dimensions (WxDxH mm)	570x545x657
Internal Dimensions (WxDxH mm)	450x420x380
Noise level	45 dB(A)
Consumption	2.83 kWh/24h
Capacity	50 L
Rated Power	160 W
Net Weight	42 Kg
Temperature	L1 (-15°C--18°C)
Gross Weight	46 Kg
Packaging dimensions (WxDxH mm)	615x615x725
Loading quantities 20'/40'/40'HQ	81/171/171

PRODUCT DIMENSIONS

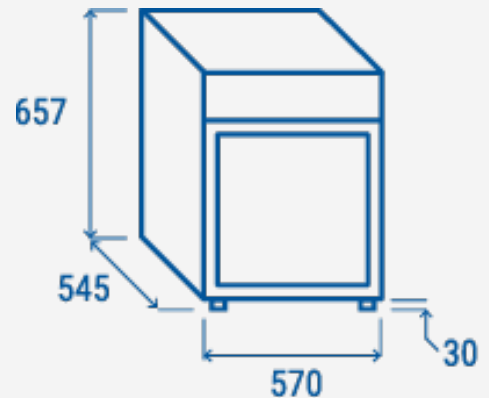

CERTIFICATION

CE RoHS



RIGHTWAY ASIA
We make the world a cooler place