

# INOX | Upright Cabinets

REFRIGERATED CABINETS ▶ GN2/1-NO FROST ▶ CHILLER

RPM 7

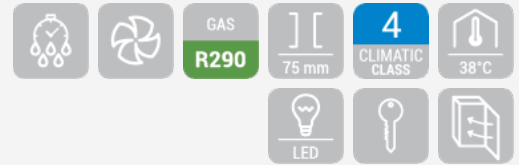

## DETAILS



The items can be supplied either with adjustable feet or lockable castor

Curved edge for easy cleaning



## GENERAL FEATURES

- GN2/1 Refrigerated upright cabinet (SPLIT DOOR)
- Stainless Steel exterior and interior
- Plastic thermal-braker as chamber body frame (Hot pipe system)
- Ventilated Cooling
- Automatic compressor cycle defrost
- Foaming Agent Cyclopentane (75mm)
- Curved edge for easy cleaning
- Digital Thermostat
- Lock and main switch fitted as standard
- Inner LED light
- Removable Gasket
- Door with self closing door
- Foamed door handle
- Adjustable shelves GN2/1: 4 pcs
- N.4 S/S Adjustable feet - (Lockable castor as Optional)
- Energy efficiency class: C

## TECHNICAL SPECIFICATIONS

Capacity	<b>580 L</b>
Temperature	<b>0° - +8°C</b>
Consumption	<b>1.75 kWh/24h</b>
Rated Power	<b>250 W</b>
Noise level	<b>49 dB(A)</b>
Net Weight	<b>112 Kg</b>
Gross Weight	<b>122 Kg</b>
External Dimensions (WxDxH mm)	<b>700x880x2043</b>
Internal Dimensions (WxDxH mm)	<b>553x698x1426</b>
Packaging dimensions (WxDxH mm)	<b>740x900x2143</b>
Loading quantities 20'/40'/40"HQ	<b>18/39/39</b>

## CERTIFICATION

CE RoHS

## PRODUCT DIMENSIONS

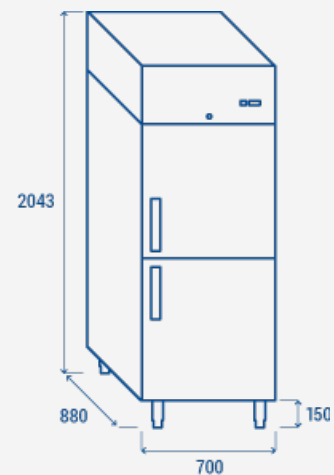

**RIGHTWAY ASIA**  
We make the world a cooler place