

INOX | Saladette

SALADETTE ▶ GN1/1 ▶ OPEN TOP



GENERAL FEATURES

- GN1/1 Refrigerated saladette (OPEN TOP)
- Stainless Steel exterior and interior
- Static cooling with fan assisted cooling
- Automatic compressor cycle defrost
- Foaming Agent Cyclopentane (35mm per side)
- Digital Thermostat
- Independent main switch
- Foamed door handle
- Easy removable condenser filter
- Separated plastic water tray
- Front panel tilted holes for better air circulation
- Adjustable shelves GN1/1: 2 Pcs
- Removable Gasket
- N.2 Adjustable feet + N.2 Rollers at the back
- Holder spacer for GN pans with "hook" design (included)
- Energy efficiency class: -

TECHNICAL SPECIFICATIONS

Capacity	247 L
Temperature	+2° - +10°C
Consumption	3.39 kWh/24h
Rated Power	263 W
Noise level	48 dB(A)
Net Weight	70 Kg
Gross Weight	81 Kg
External Dimensions (WxDxH mm)	900x700x865
Internal Dimensions (WxDxH mm)	830x595x455
Packaging dimensions (WxDxH mm)	930x730x1000
Loading quantities 20'/40'/40'HQ	36/72/72

CERTIFICATION

CE  RoHS

S 900 STD



DETAILS



PRODUCT DIMENSIONS

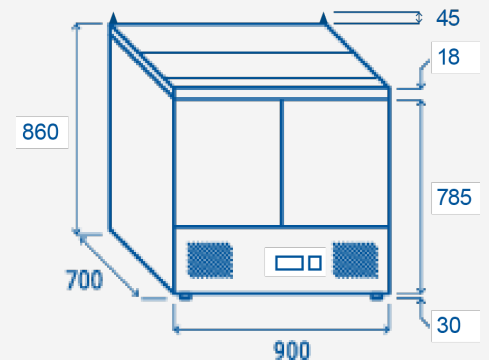

RIGHTWAY ASIA
We make the world a cooler place