

INOX | Saladette

SALADETTE ▶ GN1/1 ▶ OPEN TOP

S 903 SQ





GAS
R290

35 mm

4
CLIMATIC CLASS

36°C



DETAILS



All shelves mounted with anti-tipping system



Inner assistance fan



Curve glass



Curved tempered glass with middle shelf

GENERAL FEATURES

- GN1/1 Refrigerated saladette (OPEN TOP)
- Stainless Steel exterior and interior
- Static cooling with fan assisted cooling
- Automatic compressor cycle defrost
- Foaming Agent Cyclopentane (35mm per side)
- Digital Thermostat
- Independent main switch
- Foamed door handle
- Easy removable condenser filter
- Separated plastic water tray
- Front panel tilted holes for better air circulation
- Adjustable shelves GN1/1: 3 pcs
- Removable Gasket
- N.2 Adjustable feet + N.2 Rollers at the back
- Holder spacer for GN pans with "hook" design (included)
- Energy efficiency class: -

TECHNICAL SPECIFICATIONS

Capacity	368 L
Temperature	+2° - +10°C
Consumption	7.9 kWh/24h
Rated Power	332 W
Noise level	52 dB(A)
Net Weight	140 Kg
Gross Weight	159 Kg
External Dimensions (WxDxH mm)	1365x700x1270
Internal Dimensions (WxDxH mm)	1295x595x455
Packaging dimensions (WxDxH mm)	1395x730x990
Loading quantities 20'/40'/40"HQ	24/48/48

CERTIFICATION

CE  RoHS

PRODUCT DIMENSIONS

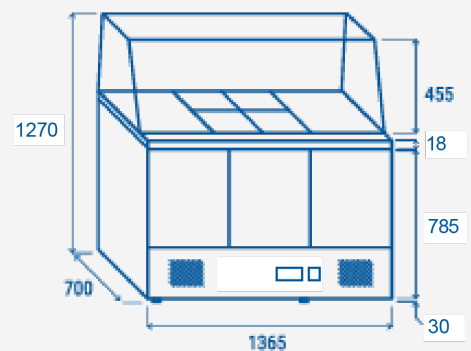

RIGHTWAY ASIA
We make the world a cooler place