

# ABS | Upright Cabinets

FREEZER UPRIGHT ▶ WHITE PAINTED

UF 2



## DETAILS



## GENERAL FEATURES

- 200 Lt. Freezer upright
- White external cabinet, thermoformed internally
- Static cooling: fixed evaporator shelves (N.2 Layers, one on the bottom)
- Additional upper removable shelves: 1 Pcs
- Manual Defrost
- Foaming Agent Cyclopentane (70mm per side)
- Digital Thermostat
- Independent back-lit main switch (White color)
- Removable Gasket and handle along door profile
- Reversible door (No self closing)
- Doors lock fitted as standard
- N.2 Adjustable feet + N.2 Rollers at the back
- Energy efficiency class: -

## TECHNICAL SPECIFICATIONS

Capacity	<b>200 L</b>
Temperature	<b>-22°C - -15°C</b>
Consumption	<b>1.869 kWh/24h</b>
Rated Power	<b>130 W</b>
Noise level	<b>62 dB(A)</b>
Net Weight	<b>38 Kg</b>
Gross Weight	<b>42 Kg</b>
External Dimensions (WxDxH mm)	<b>600x625x853</b>
Internal Dimensions (WxDxH mm)	<b>458x476x603</b>
Packaging dimensions (WxDxH mm)	<b>640x660x890</b>
Loading quantities 20'/40'/40"HQ	<b>54/108/162</b>

## PRODUCT DIMENSIONS

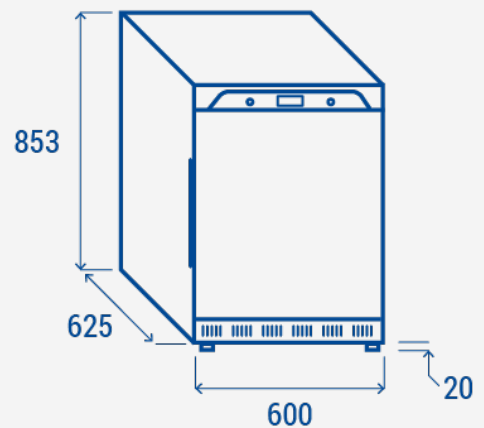

## CERTIFICATION

