

ABS | Upright Cabinets

FREEZER UPRIGHT ▶ BLACK PAINTED



UF 2B

- 
- 
-  GAS
R600a
-  70 mm
-  **4**
CLIMATIC CLASS
-  38°C
- 

DETAILS

- 
Main switch and digital thermostat fitted as standard
- 
Foamed door handle
- 
Lock fitted as standard
- 
Evaporator bottom layer
- 
Additional removable shelf

GENERAL FEATURES

- 200 Lt. Freezer upright •
- External in black coated plate, white thermoformed internally •
- Static cooling: fixed evaporator shelves (N.2 Layers, one on the bottom) •
- Additional upper removable shelves: 1 Pcs •
- Manual Defrost •
- Foaming Agent Cyclopentane (70mm per side) •
- Digital Thermostat •
- Independent back-lit main switch (White color) •
- Removable Gasket and handle along door profile •
- Reversible door (No self closing) •
- Doors lock fitted as standard •
- N.2 Adjustable feet + N.2 Rollers at the back •
- Energy efficiency class: - •

TECHNICAL SPECIFICATIONS

Capacity	200 L
Temperature	-22°C - -15°C
Consumption	1.869 kWh/24h
Rated Power	130 W
Noise level	62 dB(A)
Net Weight	38 Kg
Gross Weight	42 Kg
External Dimensions (WxDxH mm)	600x625x853
Internal Dimensions (WxDxH mm)	458x476x603
Packaging dimensions (WxDxH mm)	640x660x890
Loading quantities 20'/40'/40"HQ	54/108/162

CERTIFICATION

CE  RoHS

PRODUCT DIMENSIONS

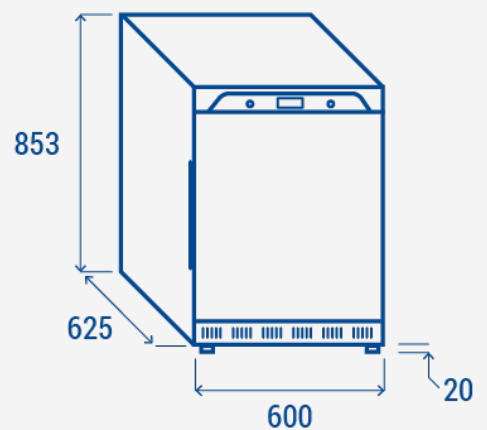

RIGHTWAY ASIA
We make the world a cooler place