

ABS | Upright Cabinets

FREEZER UPRIGHT ▶ INOX



UFX 2

-
-
-
-
-
-
-

DETAILS

Main switch and digital thermostat fitted as standard

Foamed door handle

Lock fitted as standard

Evaporator bottom layer

Additional removable shelf

GENERAL FEATURES

- 200 Lt. Freezer upright •
- S/S external cabinet, thermoformed internally •
- Static cooling: fixed evaporator shelves (N.2 Layers, one on the bottom) •
- Additional upper removable shelves: 1 Pcs •
- Manual Defrost •
- Foaming Agent Cyclopentane (70mm per side) •
- Digital Thermostat •
- Independent back-lit main switch (White color) •
- Removable Gasket and handle along door profile •
- Reversible door (No self closing) •
- Doors lock fitted as standard •
- N.2 Adjustable feet + N.2 Rollers at the back •
- Energy efficiency class: - •

TECHNICAL SPECIFICATIONS

Capacity	200 L
Temperature	-22°C - -15°C
Consumption	1.869 kWh/24h
Rated Power	130 W
Noise level	62 dB(A)
Net Weight	37 Kg
Gross Weight	41 Kg
External Dimensions (WxDxH mm)	600x625x853
Internal Dimensions (WxDxH mm)	458x476x603
Packaging dimensions (WxDxH mm)	640x660x890
Loading quantities 20'/40'/40"HQ	54/108/162

CERTIFICATION

CE RoHS

PRODUCT DIMENSIONS

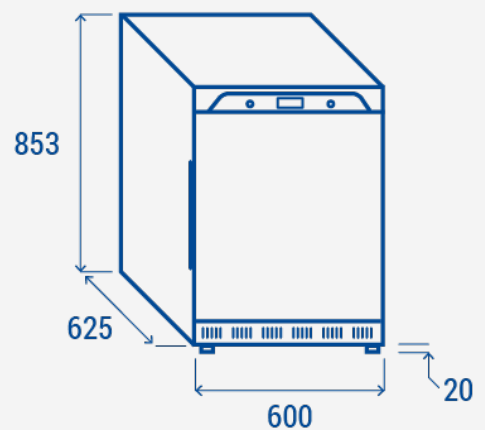

RIGHTWAY ASIA
We make the world a cooler place