

ABS | Upright Cabinets

FREEZER UPRIGHT ▶ GLASS DOOR ▶ INOX



UFXG 2

DETAILS

GENERAL FEATURES

- 200 Lt. Freezer upright (GLASS DOOR)
- S/S external cabinet, thermoformed internally
- Static cooling: fixed evaporator shelves (N.2 Layers, one on the bottom)
- Additional upper removable shelves: 1 Pcs
- Manual Defrost
- Foaming Agent Cyclopentane (70mm per side)
- Triple HEATED tempered glass with Low-e (Low emissivity glasses) and Argon gas
- Digital Thermostat
- Independent back-lit main and lights switches (White color)
- Double vertical LED light along door profile
- Removable Gasket and handle along door profile
- Doors lock fitted as standard
- N.2 Adjustable feet + N.2 Rollers at the back
- Energy efficiency class: -

TECHNICAL SPECIFICATIONS

Capacity	200 L
Temperature	-20°C - -15°C
Consumption	3.4 kWh/24h
Rated Power	285 W
Noise level	62 dB(A)
Net Weight	49 Kg
Gross Weight	53 Kg
External Dimensions (WxDxH mm)	600x625x853
Internal Dimensions (WxDxH mm)	458x476x603
Packaging dimensions (WxDxH mm)	640x660x890
Loading quantities 20'/40'/40"HQ	54/108/162

CERTIFICATION

CE RoHS

PRODUCT DIMENSIONS

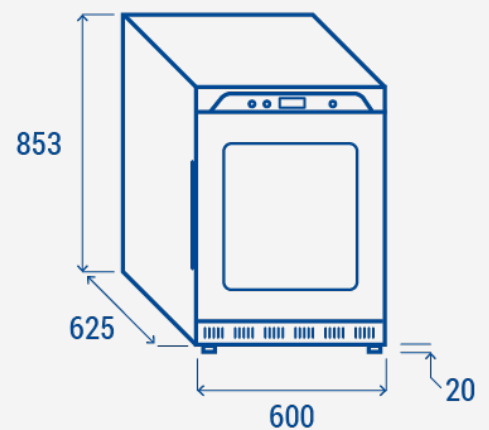

RIGHTWAY ASIA
We make the world a cooler place